

SPONSORSHIP



This work is realized within the research team **Technology, Quality and Agro-food Innovations (TQIÀ)**, within the framework of the project "**Durable Production of cassava in Central Africa and integration to the market** " (Subvention contract n°DCI-FOOD/2010/252-886) piloted by **PRASAC** (Regional Pole of Industrial research to the development of Agricultural Systems in Central Africa), with the complementary support of AIRD (Inter establishment Agency for Research and Development).

DEDICATION



THIS WORK IS DEDICATED TO GOD ALMIGHTY
AND TO THE ENTIRE T.B. NIKOBO 'S FAMILY

AMELIORATION OF THE LOCAL PRACTICE OF GARI PRODUCTION: CASE STUDY MUYUKA PRODUCTION ZONE

ACKNOWLEDGEMENTS

First of all, I want to thank the Almighty God for seeing me through this work in good health and throughout my stay in Ngaoundere. I am so grateful so I say Thank You Lord.

I want to equally acknowledge the Director of ENSAI for the peaceful and good study condition throughout my training in his institution.

My sincere gratitude goes to all the staffs and lecturers of ENSAI particularly to Pr. NDJOUENKEU Robert for offering me this internship in order to crown my training as an engineer and also for his continuous follow up and guidance to ensure the success of this work

I also want to express my gratitude to Dr. NGUIMBOU Richard for his concern and explanations as a teacher in order for this work to be realized not leaving out M. BINDZI Jean Marcel and NGOUALEM Franck who were there to ensure the smooth running of the laboratory analyses and for their corrections.

I want to thank my father Mr T.B. Nikobo and my mother Ma Emilia Misodi for their financial and moral support throughout my stay in Ngaoundere and also my brother Nanje Jekell and my sisters Ida Diale, Lokende Ernestine, Hellen Iye, Belinda Besua and Mangoh Nidaline my niece for always being there for me.

I want to acknowledge Mr. FINJAP Ernest for accommodating me in Muyuka during the diagnostic study of this work.

I also want to thank Mr. Mosongo Edward in Muyuka for the help he offered to me during my stay in there.

And finally I want to thank all my classmates particularly NKAFU, AWANA, NKENNE, and MONTHÉ for their support throughout the period of this internship.

AMELIORATION OF THE LOCAL PRACTICE OF GARI PRODUCTION: CASE STUDY MUYUKA PRODUCTION ZONE

Table of contents

SPONSORSHIP	
DEDICATION	i
ACKNOWLEDGEMENT	ii
ABSTRACT	v
RESUME	vi
LISTS OF TABLES	vii
LISTS OF FIGURES	viii
ABBREVIATIONS	ix
GENERAL INTRODUCTION	1
1 LITERATURE REVIEW	Erreur ! Signet non défini.
1.1 Introduction	3
1.2 CASSAVA	3
1.2.1 ORIGIN	3
1.2.2 TAXONOMY	3
1.2.3 Ecology and morphology	4
1.2.4 PRODUCTION AND CONSMPTION	7
1.2.5 CHEMICAL AND NUTRIONAL COMPOSITION	10
1.2.6 Cassava and Cyanogenic glucosides	12
1.2.7 Cassava post-harvest deterioration	13
1.2.8 CASSAVA PROCESSING	14
1.3 GARI	16
1.3.1 Introduction	16
1.3.2 Processing	16
1.3.3 Harvesting and sorting	18
1.3.4 Gari processing Scales or levels	21
1.4 Types of gari	22
1.5 Production and Consumption of gari	22
1.6 Criteria of quality gari	23
2 PART ONE: DIAGNOSTIC STUDY ON GARI PRODUCTION: CASE STUDY MUYUKA	
26	
2.1 INTRODUCTION	26
2.2 MATERIALS AND METHOD	27
2.2.1 Study area	27
2.2.2 Diagnosis	27
2.2.3 Questionnaire	27

AMELIORATION OF THE LOCAL PRACTICE OF GARI PRODUCTION: CASE
STUDY MUYUKA PRODUCTION ZONE

2.2.4	Data analysis	28
2.3	RESULTS AND DISCUSSION	30
2.3.1	Major actors in gari production.....	30
2.3.2	Primary material.....	32
2.3.3	Transformation process	34
2.3.4	Transformation capacity/ Mass yield	35
2.3.5	Duration of unit Operations	36
2.3.6	Quality of gari.....	37
2.4	ECONOMIC EVALUATION	39
2.4.1	Calculation of Working Capital	40
2.5	PARTIAL CONCLUSION.....	42
3	PART TWO: QUALITY OF PRODUCT	Erreur ! Signet non défini.
3.1	INTRODUCTION.....	42
3.2	MATERIALS AND METHODS.....	43
3.2.1	Materials	43
3.2.2	Methods	44
3.2.3	Physicochemical Analyses.....	44
3.2.4	Dry Matter/ Moisture Content	44
3.2.5	Techno functional Properties	51
3.2.6	Pasting properties	52
3.2.7	SENSORY ANALYSES	53
3.3	Statistical analyses.....	54
3.4	RESULTS AND DISCUSSION	55
3.4.1	Physicochemical and functional characterization of gari samples.....	55
3.5	Sensory Analysis	60
3.5.1	Pre –test	61
3.5.2	Main test	61
4	PARTIAL CONCLUSION.....	67
	PROPOSED AMELIORATIONS.....	Erreur ! Signet non défini.
4.1	Advantages of model.....	69
5	AN ECONOMICALLY CONVINIENT GARI PRODUCING MODELErreur ! Signet non défini.	
	REFERENCES.....	83
	ANNEXES	A

AMELIORATION OF THE LOCAL PRACTICE OF GARI PRODUCTION: CASE STUDY MUYUKA PRODUCTION ZONE

ABSTRACT

In view of enhancing the value of gari produced in Cameroon, in order to increase its marketing potential this present study was envisaged with main objective to ameliorate the local practice of gari production with case study in the Muyuka production zone. In order to attain these objectives, a survey study was carried out where gari samples were prepared using both the traditional and improved pressing methods, fermentation period varied from 0-3 days using three pure varieties of cassava and a financial evaluation of the activity was done. The resulting gari were then evaluated for their Physicochemical and functional properties (HCN content, titratable acidity, ash, total starch, WAC, and pasting properties) and a sensory analysis was performed using Qualitative Descriptive Analyses (QDA). Results obtained were then analysed using XLSTAT 2007 and Statgraphics XVI. Survey results show that gari is produced mainly at household level, major market constraints being price fluctuations and low demand and financial evaluation for a producer who transforms 235 kg of cassava per production, twice a week gave a negative balance - 430100FCFA over a period of one year. But using a model that transforms 5 tons of cassava per day gave that the breakeven point can be attained during the first year of production. Pressing method had no significant effect on the physicochemical and functional properties of the gari samples ($P < 0.05$). The fermentation time had a significant effect on most of these parameters ($P < 0.05$). The varieties also had a significant effect on these parameters ($P < 0.05$). Cyanide content of gari samples decreased with increase fermentation time with decrease significantly different. Other parameters like the starch content, titratable acidity and ash content showed some significant differences but not as in the case of HCN. Results from sensory analysis showed that gari samples can be classified based on the cassava varieties and fermentation time into four main classes. Same number of classes were obtained after performing an Agglomerative Hierarchical Clustering (AHC). Comparing results of sensory and physicochemical and functional analysis showed that the parameters like acidity of gari was not well perceived by the panelists. Using a model that transforms 5 tons of cassava daily gives that the BEP will be attained after a period of 1 year 6 months with a cumulative cashflow of **668254143.1**Fcfa at the end of the five years period. Gari production is a promising sector that investing more resources will render it very profitable and in terms of the quality of product, in order to obtain a product with total low total cyanide level, demands a fermentation time of at least three days.

Keywords: Fermentation time, cassava varieties, Hydrogen cyanide, gari, pressing methods

AMELIORATION OF THE LOCAL PRACTICE OF GARI PRODUCTION: CASE STUDY MUYUKA PRODUCTION ZONE

RESUME

Afin d'augmenter la valeur du gari produit au Cameroun, il nous faut stabiliser son potentiel marchande. Ce travail a donc été envisagé ayant pour objectif principal l'amélioration de la pratique locale de production du gari sur la zone de Muyuka. Pour atteindre ces objectifs, une étude d'aperçu a été effectuée pour identifier les procédés et contraintes liées à la production, des échantillons de gari ont été préparés en utilisant les méthodes de pression traditionnelles et améliorées, période de fermentation de 0-3 jours et en utilisant trois variétés pures de manioc et une évaluation financière de l'activité a été faite. Le gari résultant a été alors évalué pour leurs propriétés physico-chimiques, fonctionnelles (comme le teneur en HCN, l'acidité titrable, les cendres, l'amidon total, le WAC, et les propriétés gélifiantes) et une analyse sensorielle a été faite en utilisant les analyses descriptives qualitatives (QDA). Des résultats obtenus ont été analysés en utilisant Sphinx plus², XLSTAT 2007 et Statgraphics XVI. Les résultats de l'enquête prouvent que le gari est produit principalement au niveau de ménage et avec le même procédé dans tous les ménages. Les contraintes comme insuffisance des machines et rupture de matière première l'évaluation financière a donné un équilibre négatif -430100fcfa pendant un an. Mais le modèle qu'on a proposé qui transforme 5 tons par jour donne le BEP à la première année de production. La pression de la méthode n'a eu aucun effet significatif sur les propriétés physico-chimiques et fonctionnelles des échantillons de gari ($P < 0.05$). Le temps de fermentation a eu un effet significatif sur la plupart de ces paramètres ($P < 0.05$). Les variétés ont également eu un effet significatif sur ces paramètres ($P < 0.05$). La teneur en cyanure des échantillons de gari a diminué avec du temps de fermentation avec la diminution significativement différente. D'autres paramètres comme la teneur en amidon, l'acidité titrable et les cendres ont montré quelques différences significatives mais pas comme dans le cas de HCN. Les résultats d'analyse sensorielle ont prouvé que des échantillons de gari peuvent être classifiés basés sur les variétés de manioc et le temps de fermentation dans quatre classes principales. Le même nombre de classes ont été obtenus après exécution de groupement hiérarchique agglomératif (AHC). Comparer des résultats d'analyse sensorielle et physico-chimique et fonctionnelle a prouvé que les paramètres comme l'acidité du gari n'ont pas été bien perçus par les panelistes. La production de Gari est un secteur promoteur qui quand plus de ressources sont investies rendra le secteur profitable et en termes de qualité de produit, afin d'obtenir un niveau plus bas de cyanure de produit, demande un temps de fermentation d'au moins trois jours.

Mots clés: période de fermentation, variétés de manioc, le cyanure (HCN), méthode de Pearson

AMELIORATION OF THE LOCAL PRACTICE OF GARI PRODUCTION: CASE STUDY MUYUKA PRODUCTION ZONE

LISTS OF TABLES

Table 1: Classification of cassava.....	4
Table 2: The major cassava producing countries in 2010 (data from FAO, 2012).....	7
Table 3: Affection of cassava produced in some producer Countries	9
Table 4: Cultivated area and cassava production in cCameroon for the year 2010.....	10
Table 5: Chemical composition of cassava roots and leaves, (Buitrago, 1990)	11
Table 6: gari classification with respect to particle sizes	24
Table 7: gari composition.....	24
Table 8: Gender, age and marital status of actors in the gari sector	30
Table 9: Cost of raw Material.....	40
Table 10: Calculation of depreciation cost.....	40
Table 11: Calculating cost of production	41
Table 12: differential cost calculation.....	41
Table 13: Standard curve for cyanide quantification	47
Table 14: Standard curve for starch determination	48
Table 15: Sample preparation for starch determination	49
Table 16: ANOVA table for the variation of physicochemical and functional parameters as a function of pressing method.....	55
Table 17: ANOVA table showing variation of physicochemical and functional properties with fermentation time	55
Table 18: ANOVA table of physicochemical parameters of gari with respect varieties of cassava	56
Table 19: Classes of gari samples with respect to their sensory attributes.....	65

AMELIORATION OF THE LOCAL PRACTICE OF GARI PRODUCTION: CASE STUDY MUYUKA PRODUCTION ZONE

LISTS OF FIGURES

Figure 1: cassava plant.....	5
Figure 2: cross-section of a cassava storage root (IITA, 1990)	7
Figure 3: major cassava products and processing methods	15
Figure 4: Traditionl process of gari production	17
Figure 5: general structure of present work.....	25
Figure 6: sample preparation	29
Figure 7: nature of gari processing units	31
Figure 8: nature of raw material and time lapse before processing	32
Figure 9: obtention of raw material	33
Figure 10: reason for preferences over varieties.....	33
Figure 11: process flow diagram of all processors	34
Figure 12: Quantity of cassava transformed by processors.....	35
Figure 13: amount of gari obtained.....	35
Figure 14: Quality parameters of processors.....	37
Figure 15: labor sources	38
Figure 16: financing of production	38
Figure 17: profitability as assessed by producers	39
Figure 18: The University of Ibadan model	69
Figure 19: Ibadan improved traditional fryer	70
Figure 20: standard curve for cyanide determination	Erreur ! Signet non défini.

AMELIORATION OF THE LOCAL PRACTICE OF GARI PRODUCTION: CASE STUDY MUYUKA PRODUCTION ZONE

ABBREVIATIONS

PRASAC-

PCA- PRINCIPAL COMPONENT ANALYSIS

QDA- Qualitative Descriptive Analysis

AHC- AGGLOMERATIVE HIERARCHICAL CLUSTERING

IITA- International Institute of Tropical Agriculture

SSA- Sub-Saharan Africa

ANOVA: Analyses of Variances

AACC: American Association of Cereal Chemists

FAOSTAT: Food and Agricultural Organization Statistics

DM: Dry matter

FAOSTAT: Food and Agricultural Organization Statistics

RVA: Rapid Visco-Analyser

WAC: Water Absorption Capacity

WHO: World Health organization

ENSAI : Ecole Nationale Supérieure des Sciences Agro-Industrielles

mg/kg: milligrams per kilogram

HCN: Hydrocyanic acid

HCl: hydrochloric acid

KOH: Potassium hydroxide

Kumba-0: gari from Kumba stick that was unfermented

Kumba-1: gari from Kumba stick that undergone one day fermentation

Kumba-2: gari from Kumba stick that undergone two days of fermentation

Kumba-3: gari from Kumba stick that undergone three days of fermentation

8017-0: gari from 8017 that was not fermented

AMELIORATION OF THE LOCAL PRACTICE OF GARI PRODUCTION: CASE STUDY MUYUKA PRODUCTION ZONE

8017-1: gari from 8017 that undergone one day fermentation

8017-2: gari from 8017 that undergone two days of fermentation

8017-3: gari from 8017 that undergone three days of fermentation

Owe-0: gari from Owe stick that was not fermented

Owe-1: gari from owe stick that undergone one day fermentation

Owe-2: gari from owe stick that undergone two days of fermentation

Owe-3: gari from owe stick that undergone three days of fermentation

IP: profitability Index

BEP: Break even point

CF: Cash Flow

PIDMA Integration program of Cassava in to the Agricultural Market

AMELIORATION OF THE LOCAL PRACTICE OF GARI PRODUCTION: CASE STUDY MUYUKA PRODUCTION ZONE

GENERAL INTRODUCTION

According to wikipedia, the free encyclopedia, a staple food sometimes referred to as staple is a food that is eaten routinely, and in such quantities that it constitutes a dominant portion of a standard diet in a given population, supplying a large fraction of the needs for energy-rich materials and generally a significant proportion of the intake of other nutrients as well. According to FAOSTATS, (2010), most people live on a diet based on just a small number of staples. Staple foods vary from place to place, but typically they are inexpensive or readily available foods that supply one or more of the three organic macronutrients needed for survival and health: carbohydrates, proteins, and fats. Among all these staples, cassava is a major staple food in the developing world, with over half a billion people in Africa, Asia and Latin America depending on it for their basic diet and for their income (Nweke, 2004). Cassava is consumed by about 500 million Africans every day, cassava is the second most important source of carbohydrate in sub-Saharan Africa, after maize (Lebot, 2008). Sub-Saharan Africa produces more than 50 percent of the world's cassava output, mainly for subsistence usage. In West and Central Africa, cassava is typically grown by poor farmers, many of them women, often on marginal lands. It is said to provide a living for more than 40 million people in the region, mainly in rural areas. But cassava is often seen as a “poor cousin” in the world's family of staple crops. Far less research and development have been devoted to cassava compared to rice, maize and wheat. This lack of scientific interest has contributed to highly uneven cultivation and processing methods, and cassava products that often are of poor quality (Sanyang *et al.*, 2014). Increases in its production are mostly due to increased surface area rather than higher yields per hectare. And even where yields do increase, this does not necessarily translate into higher incomes. In order to change this notion about this plant in favour to its technological, industrial and commercial advancements, many national and international programs have been put in place in many African countries. Among these programs we can cite PNDRT (National Program for the Development of Roots and Tubers), PIDMA (Investment and development projects on Agricultural Markets), and other projects carried out by the Ministry of Agriculture and Rural Development (MINADER). At sub regional level CEMAC (Economic Communities of Central African States), the project, << Valorization of cassava and integration into the Market>> controlled by PRASAC (Pôle Régional de Recherche Appliquée au Développement des Systèmes Agricoles d’Afrique Centrale) and finally International Institute of Tropical Agriculture (IITA) involved in the development of new cassava varieties.

In Cameroon, cassava represents 70% of the total cultivated area and 46% of food crop production. Sub Saharan countries generally are characterized by their low income and deficit of food crops where the main part of their production, about 93% of the produce is used as

AMELIORATION OF THE LOCAL PRACTICE OF GARI PRODUCTION: CASE STUDY MUYUKA PRODUCTION ZONE

food (Nweke *et al.*, 2002). With respect to this, 80% of urban households in Cameroon consume cassava on a daily basis (Sanyang *et al.*, 2014), and the share of urban consumption of cassava was 42% (in 2009).

However, the post-harvest use of fresh cassava tubers encounter two major constraints: perishability due to its high moisture content and toxicity related to the presence of cyanogenic compounds in the root (). To overcome these limitations, the fresh root is processed into more stable and non-toxic products (chips, gari, sticks and flour) through retting. In addition to producing storable products, processing can also add value to the crop and provide employment opportunities. In Cameroon, the most common products of cassava are: gari, *waterfufu*, *cossettes*, *bobolo*, *mintoumba*, *miondo* and starch (Tiky Mpondo, 1993).

In West Africa, gari is the most consumed and traded of all food products made from cassava roots (Oti *et al.*, 2011). The acceptance and popularity of gari in urban and rural areas of West and Central Africa is attributed to its ability to store well, its convenience and ready-to-eat form (Flach, 1990). But the quality of this product is highly variable; this can be due to either the process or the high variability of cassava varieties. In addition, it is widely claimed that there is inter- and intra-communal variability in cassava processing techniques due to a clear lack of standardization (NRI, 1989; Nweke, 1994) that has been reported to produce foods with variable organoleptic properties and different levels of residual cyanohydrin and HCN (Banea *et al.*, 1992). These residual compounds have been incriminated for the toxicity associated with the continued ingestion of insufficiently processed cassava (Mlingi *et al.*, 1992; Tylleskar, 1994). To standardize the cassava products' market and to add value to this crop, the process and the influence of this process to the quality of *gari* ought to be carry out. It is for these reasons that the present work was carried out with the main objective to ameliorate the local practice of *gari* production. And as specific objectives:

- To do a diagnostic study on gari production
- Product analysis
- Propose elements for the valorisation of systems
- Propose possible ameliorations

AMELIORATION OF THE LOCAL PRACTICE OF GARI PRODUCTION: CASE STUDY MUYUKA PRODUCTION ZONE

Introduction

Cassava scientifically called *Manihot esculenta* (Asiedu, 1990; Akinlosoye and Babarinde, 2009) and botanically a member of the *Manihot Utilissima* is a starchy, root crop, grown throughout the tropical world. Cassava is second only to sweet potato as the most important starchy root crop (Grace, 1977) and it is known around the globe for its trade values as starchy crop, food and feed crop. Its roots are perishable and contain potentially toxic cyanogenic glucosides (Sanni, *et al.*, 1994). Therefore, they are processed exclusively for human consumption in. It is an important tropical plant serving the following importance, source of industrial starch granules, important in chemical processing of ethanol and other substances, source of flour, and the peeled roots can be crushed and fermented before frying to produce a “semi-dextrin food stuff” called Gari among others (Akinlosoye and Babarinde, 2009). Gari is the most popular staple food derived from cassava and it is a creamy-white, granular flour with a slightly fermented flavour and a slightly sour taste made from fermented, gelatinized fresh cassava roots (International Institute of Tropical Agriculture (IITA, 2005).

0.1 CASSAVA

0.1.1 ORIGIN

Cassava has its genetic, geographical and agricultural origin in Latin America (Olsen and Schaal, 1999, Hillocks, 2002). Its domestication began 5000 – 7000 years BC in the Amazon, Brazil and it was distributed by Europeans to the rest of the world (Allen, 2002; Henry & Hershey, 2002). Cassava was taken from Brazil to the West Coast of Africa by Portuguese navigators in the 16th century (Jones, 1959, Nweke, 1994). Cassava was brought to East Africa in the 18th century by the Portuguese from Cape Verde and into Mozambique from Zanzibar Island (Leitão, 1970).

0.1.2 TAXONOMY

Cassava, as known in English, is “manioc” in French, “yuca” in Spanish, and “mandioca” in Portuguese (Gade, 2002). It belongs to the class Dicotyledoneae, family Euphorbiaceae, tribe Manihoteae, genera *Manihot* Tournefort and species *Manihot esculenta* Crantz (Alves, 2002). Early literature on cassava described the genus as having two edible species, *Manihot utilissima* Phol and *Manihot aipi* Phol delineating cultivars with high and low cyanogenic glucoside concentration respectively. Cassava has recently been classified as being one

AMELIORATION OF THE LOCAL PRACTICE OF GARI PRODUCTION: CASE STUDY MUYUKA PRODUCTION ZONE

species, *Manihot esculenta* Crantz (Onwueme, 1978). The taxonomy can be represented as follows:

Table 1: Classification of cassava (Alves, 2002)

Ranks	Scientific and common names
Kingdom	Plantae- Plants
Subkingdom	Tracheobionta
Superdivision	Spermatophyta
Division	Magnoliphyta
Class	Magnoliopsida
Subclass	Rosidea
Order	Euphorbiales
Family	Euphorbiaceae
Genus	Manihot
Species	<i>Manihot esculenta</i> , Crantz- Cassava

0.1.3 Ecology and morphology

0.1.3.1 Ecology

Cassava is a tropical crop, a perennial shrub of the Euphorbiaceae family, distributed between latitudes 30° N and 30° S (Costa and Silva, 1992; Alves, 2002). The ideal growth temperature range is 24 to 30°C (IITA, 1990) but it can tolerate temperatures ranging from 16 to 38°C. Cassava can grow in the semi-arid tropics with an annual rainfall less than 800 mm, but the ideal rainfall is 1000 to 1500 mm per year (Alves, 2002). Cassava can grow in low-nutrient soils where cereals and other crops do not grow. It grows well in sandy to light soils where the storage roots can develop easily. Cassava can tolerate soils with low pH (Islam *et al.*, 1980). Soils with a superficial hard layer or with many stones are not suitable for cassava growth.

0.1.3.2 Morphology

Cassava is a perennial woody shrub of one to three metres in height with edible tuberous roots arising from stem cutting, but farmers mostly grow it as an annual crop (Onwueme, 1978; Lozano *et al.*, 1980; IITA, 1990; 2001; Benesi, 2002; Nassar, 2005). It is propagated mainly from stem cuttings but during plant breeding and under natural conditions, propagation is by sexual seed in the first cycle (Onwueme, 1978; IITA, 1990;

AMELIORATION OF THE LOCAL PRACTICE OF GARI PRODUCTION: CASE STUDY MUYUKA PRODUCTION ZONE

Nassar, 2005). Cassava tuberous roots are composed of a peel which represents about 10-20% of the tuberous root. The cork layer represents 0.5-2.0% of the total tuberous root weight. The fleshy edible portion makes up 80-90% of the tuberous root and is composed of 60-65% water, 30-35% carbohydrate, 1-2% protein, 0.2-0.4% fat, 1.0-2.0% fibre, and 1.0-1.5% mineral matter (Nassar and Costa, 1976; Onwueme, 1978; Nassar, 1986). The figure below shows a cassava plant (leaves, stem and roots).



Figure 1: cassava plant

The cassava plant is characterized by the following parts:

Stem

The stem is 1 to 4 m long and woody with a thick bark. The old part of the stem bears evident scars of fallen first leaves. The system of stem branching is controlled by genetic and environmental factors (IITA, 1990). The branching may start at any time of plant growth, producing 3 new branches and after a certain time these produce 3 more new branches each. The level of branching depends on the variety of cassava (Rulkens, unpublished).

AMELIORATION OF THE LOCAL PRACTICE OF GARI PRODUCTION: CASE STUDY MUYUKA PRODUCTION ZONE

Leaves

Cassava leaves have a long petiole and are divided into 5 to 7 lobes. New leaf and petiole colour depend on the genotype.

Roots

Roots are the main storage and the most important organ in cassava for humans. The cassava root is not a tuberous root, but a true root which cannot be used for vegetative propagation (Alves, 2002). The mature cassava storage root has four distinct tissues: bark (periderm), peel (cortex), parenchyma and central vascular xylem bundle (IITA, 1990). The parenchyma, which is the edible portion of the fresh root, comprises approximately 85% of total weight, consisting of xylem vessels radially distributed in a matrix of starch containing cells (Wheatley and Chuzel, 1993). The peel layer, which is comprised of sclerenchyma, cortical parenchyma and phloem, constitutes 11-20% of root weight. The periderm (3% of total weight) is a thin layer of cells and, as growth progresses, the outermost portions usually slough off. Root size and shape depend on cultivar and environmental conditions, the cassava root is not a tuberous root, but a true root which cannot be used for vegetative propagation (Alves, 2002). The mature cassava storage root has four distinct tissues: bark (periderm), peel (cortex), parenchyma and central vascular xylem bundle (IITA, 1990). The parenchyma, which is the edible portion of the fresh root, comprises approximately 85% of total weight, consisting of xylem vessels radially distributed in a matrix of starch containing cells (Wheatley and Chuzel, 1993). The peel layer, which is comprised of sclerenchyma, cortical parenchyma and phloem, constitutes 11-20% of root weight. The periderm (3% of total weight) is a thin layer of cells and, as growth progresses, the outermost portions usually slough off. Root size and shape depend on cultivar and environmental conditions; variability in size between cultivars is greater than that found in other root crops (Wheatley and Chuzel, 1993). The figure below shows the cross section of a cassava root.

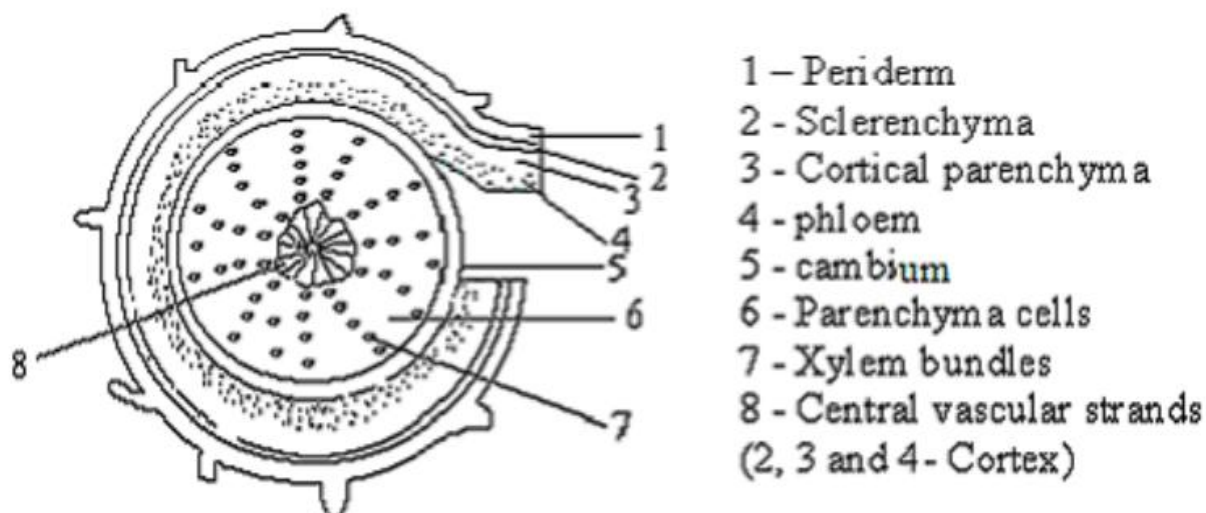

Figure 2: cross-section of a cassava storage root (IITA, 1990)

0.1.4 PRODUCTION AND CONSUMPTION

0.1.4.1 PRODUCTION

The estimated total world cassava production in 2010 was 230 million tons according to FAO (2012) Africa accounted for 54%, Asia for 28% and Latin America and the Caribbean for 19% (IITA, 2002). The major cassava producers are located in three continental regions which are Nigeria, Brazil and Thailand, accounting approximately for 20, 11 and 12% of total world production, respectively. The table below summarises the major cassava producing Countries in the World.

AMELIORATION OF THE LOCAL PRACTICE OF GARI PRODUCTION: CASE
STUDY MUYUKA PRODUCTION ZONE

Table 2: The major cassava producing countries in 2010 (data from FAO, 2012)

Countries	Root production (x1000 tonnes)		Yield (tonnes /ha)		Production per capita (Kg fresh weight)
	Fresh roots weight*	Dry	Fresh roots	Dry weight*	
Nigeria	37 500	13 100	12	4.2	230
Brasil	24 500	8 600	14	4.9	126
Indonesia	23 900	8 400	20	7.0	100
Thailand	22 000	7 700	19	6.7	314
D. R. Congo	15 000	5 300	8	2.8	231
Angola	13 800	4 800	15	5.3	726
Ghana	13 500	4 700	13	4.3	563
Vietnam	8 500	3 000	17	6.0	97
India	8 000	3 000	34	12.0	67
Mozambique	5 700	2 000	6	2.1	248
Uganda	5 300	1 900	12	4.2	161
China	4 700	1 600	17	5.9	34
Tanzania	4 400	1 500	6	2.1	64
Cambodia	4 200	1 500	20	7.0	300
Malawi	4 000	1 400	21	7.4	267

Results from the precedent table shows that Nigeria is the world's largest cassava producer. The average world cassava yield in 2010 was estimated at 12.4 tons per ha (FAO, 2012). African countries present the lowest yields and Asian countries present the highest yields. Maximum yield was reported to be 34 tons per hectare in India (FAO, 2012). Data of cassava production per capita from the precedent table show how cassava is important in Africa.

0.1.4.2 CONSUMPTION

The consumption pattern of cassava in the first ten producer Countries in the World according to FAOSTAT in 2005 is shown in the table below.

AMELIORATION OF THE LOCAL PRACTICE OF GARI PRODUCTION: CASE
STUDY MUYUKA PRODUCTION ZONE

Table 3: Affectation of cassava produced in some producer Countries

Country	National Production (millions of tons)	% for Human Consumption	% for animal feed	Other uses
Nigeria	38	43,10	25,20	31,70
Brasil	24	33,89	50,29	15,82
Thailand	21,5	31,44	0,01	68,56
DR Congo	15	90,54	5,40	4,06
South Africa	11	0,23	0,01	99,7
Madagascar	2,5	84,38	9,6	6,02
Ivory Coast	1,5	89,9	5,09	5,00
Congo	0,9	98,41	0,3	1,29
Malaysia	0,9	41,5	2,34	56,17

Source: FAOSTAT, 2005

From the table it is evident that cassava utilization patterns vary considerably in different parts of the world and it can be seen that in Africa, the majority of cassava produced (88 %) is used for human food with over 50% used in the form of processed products (Westby, 2002). Animal feed and use for starch are only minor uses of the crop.

0.1.4.3 Cassava in Cameroon

Present in almost all the Regions of the Country, it is cultivated mainly for its roots and leaves. It is predominant in the Southern Regions of the Country generally referred to as the Grand South with the main producer Regions being the Centre, Eastern, Littoral, Adamawa South West, and North West Regions with the first four supplying 70% of the national production (Agbor Egbe *et al.*, 1995). Cassava offers an affordable source of calories and contributes to household food security; as areas devoted to its cultivation was estimated at 204,548 hectares with an annual production of 2.3 million tons (PNDRT, 2005). It is mainly produced by small-holder farmers whose average cultivation area does not exceed one hectare (Njukwe *et al.*, 2014). It is primarily produced for food because processing facilities are absent and its cultivation is dominated in areas with limited infrastructural development (Njukwe *et al.*, 2014).

AMELIORATION OF THE LOCAL PRACTICE OF GARI PRODUCTION: CASE STUDY MUYUKA PRODUCTION ZONE

In terms of consumption, in the World's classification in 2005, Cameroon is the 19th consumer Country. The table below shows the total area and production of cassava in Cameroon. The present production of cassava in Cameroon is estimated at about three million tons as shown in the table below.

Table 4: Cultivated area and cassava production in Cameroon for the year 2010

Region	Surface area 2010 (hectare)	Production 2010 (tons)
Adamawa	11274	165171
Centre	86819	1198080
Eastern	64138	805387
Exreme North	474	5257
Littoral	13928	311123
North	3516	29642
North West	13768	110708
West	15100	121643
South	35467	630573
South West	26303	430694
Cameroon	270 787	3 808 239

MINADER/DESA, July 2012

Although the majority of data available for cassava relates to the roots, cassava leaves are also consumed in many African countries (Achidi *et al.*, 2005). In the Democratic Republic of Congo, cassava leaves have greater market value than roots (Lutaladio and Ezumah, 1981). It has been estimated that cassava leaves account for approximately 68% of all vegetable output in this country (Tshibaka and Lumpungum, 1989).

0.1.5 CHEMICAL AND NUTRIONAL COMPOSITION

The composition of cassava depends on the specific tissue (root or leaf) and on several factors, such as geographic location, variety, age of the plant, and environmental conditions (Gil and Buitrago 2002). The roots and leaves, which constitute 50% and 6% of the mature cassava plant, respectively, are the nutritionally valuable parts of cassava (Tewe and Lutaladio 2004). They are used for human consumption and animal feed (Buitrago 1990, Dahniya, 1994).

AMELIORATION OF THE LOCAL PRACTICE OF GARI PRODUCTION: CASE STUDY MUYUKA PRODUCTION ZONE

Generally Cassava roots contain about 60-65% moisture, 30-35 % carbohydrates on fresh weight basis and 80-90 % on dry matter basis (Balagopalan *et al*, 1988). The starch content, representing 80 % of the carbohydrates produced, reaches a peak during the 10th to 11th month after planting. However, peak starch yield differs between cassava varieties, as observed by Apea-Bah *et al.*, (2011). The composition changes slightly with increasing age as the roots become more fibrous and the starch content declines. which consists of both amylose (20%) and amylopectin (70%) (Buitrago, 1990). Generally, cassava roots have less than 1% free sugars (Bradbury and Holloway, 1988). The general chemical composition of cassava roots and leaves is shown in the table below.

Table 5: Chemical composition of cassava roots and leaves, (Buitrago, 1990)

Nutrient	Storage root		Leaves	
	Fresh weight Basis(%)	Dry weight basis (%)	Fresh weight Basis(%)	Dry weight basis (%)
Dry matter	35.00	100.00	28.00	100.00
Starch	30.21	85.10	16.23	39.00
Crude protein	1.10	3.10	6.80	24.00
Fat	0.47	1.30	1.80	6.50
Crude fibre	1.10	3.10	5.80	20.60
Ash	0.70	1.90	1.70	6.20
Calcium	0.10	0.33	0.43	1.50
Phosphorus	0.15	0.44	0.08	0.27

Cassava is a poor source of protein as it contains only 1-3% protein on dry matter basis (Montagnac *et al*, 2009) and is low in essential amino acids such as methionine, lysine, tryptophan, phenylalanine and tyrosine (Falade and Akingbala, 2010). The vitamin, mineral, and cyanide constituents of cassava root parenchyma and peel are shown in the table below.

AMELIORATION OF THE LOCAL PRACTICE OF GARI PRODUCTION: CASE STUDY MUYUKA PRODUCTION ZONE

0.1.6 Cassava and Cyanogenic glucosides

The major constraint in cassava roots as human food is the presence of toxic cyanogenic glycoside compounds in the tissues. Cassava tissues also contain the enzyme linamarase, which can hydrolyse cyanogenic glycoside but the enzyme is not located in the same cell compartments as the cyanogenic glycosides (Bruijn, 1971; Nweke, 1994; Teles, 1995). Cyanogenic glycosides are located inside vacuoles and the enzyme linamarase in the cell wall (Conn, 1994). Disruption of cassava tissues initiates the hydrolysis of cyanogenic glycosides. Cyanogenic glycoside are leached from vacuole and come into contact with linamarase, a β -glucosidase, to produce acetone cyanohydrin from linamarin and 2-butanone cyanohydrin from lotaustralin (Conn, 1994). These cyanohydrins are unstable and decompose spontaneously to the corresponding ketones and hydrogen cyanide (HCN) at pH values above 5 and temperatures above 30°C. Cyanohydrin degradation can also be catalysed by α -hydroxynitrile lyase, located in apoplastic space (White *et al.*, 1994). In all the tissues, with the exception of the seeds, cassava contains 4 to 5 cyanogenic glycosides (McMahon *et al.*, 1995). The main ones are linamarin and lotaustralin in a ratio 97:7 (Teles, 1995). The concentrations of cyanogens vary in different varieties, between tissues in the same plant and even between compartments of the same tissue (Barrios and Bressani, 1967; Bruijn, 1971; Nambisan and Sundaresan, 1994; Wheatley and Chuzel, 1993, Burns *et al.*, 2012).

The liberated HCN through the hydrolysis of cyanogenic glycosides is toxic. The HCN blocks the reduction of oxygen in the respiratory pathway (Nelson and Cox, 2008). This is achieved by it acting as a potent inhibitor of oxidase and other important enzymes in the respiratory chain (Balagopalan *et al.*, 1988).

Most common illness related to cassava consumption is due to prolong exposure to comparable low concentrations of cyanogens in ingested cassava products (Rosling, 1988). Residual cassava cyanogens, when ingested, are hydrolysed in the human digestive system. It is assumed that intestinal microbes hydrolyse the cyanogens (Teles, 1995).

Cassava varieties are often described as being bitter or sweet by reference to the taste of fresh roots and this partly correlates with cyanogen concentrations (Chiwona-Karlton *et al.*, 2004). Bitter varieties are associated with high concentrations of cyanogenic glycosides (> 100 mg/kg fresh weight) (Sundaresan *et al.*, 1987; Nambisan and Sundaresan, 1994;

AMELIORATION OF THE LOCAL PRACTICE OF GARI PRODUCTION: CASE STUDY MUYUKA PRODUCTION ZONE

Chiwona-Karlton *et al.*, 2004). Sweet varieties have a high concentration of free sugars but it does not always follow that they have low concentrations of cyanogenic glycoside (Borges and Fukuda, 1989; King and Bradbury, 1995). However, bitter taste and high level of cyanogens can also be related to environmental stress conditions, such as drought, low soil fertility and pest attack (Bruijn, 1971).

The consumption of lower cyanide amounts are not lethal but long-term intake could cause severe health problems such as tropical neuropathy (Osuntokun 1994), glucose intolerance, konzo (spastic paraparesis) (Ernesto *et al.*, 2002), and, when combined with low iodine intake, goiter and cretinism (Delange *et al.*, 1994).

However, the toxicity can be reduced to safer levels during traditional processing (Falade and Akingbala, 2010).

0.1.7 Cassava post-harvest deterioration

Freshly harvested cassava roots have a shelf life of 24 to 48 hours (Hillocks, 2002; Westby, 2002). This deterioration generally occurs by either biochemically involving some enzymatic reactions by wound response resulting in an increase enzymatic activity (Westby, 2002) or through microbial infestation of the tubers. Cassava roots with visible signs of physiological deterioration are considered to have low eating and processing qualities. Chuzel, (1991) reported poor starch extraction from deteriorated cassava roots Poor sedimentation during the starch extracted has been reported resulting from the use of deteriorated roots. Ruiz, (1991) reported that storage of roots for more than 36 hours alters the color and flavor of the resulting starch. Observations made on the implication of physiological deterioration of roots usage were compiled by Wenham, are as follows:

- Roots suffering from deterioration took longer time to cook, had an unpleasant, bitter flavor and an unattractive off flavor.
- In gari production, the use of deteriorated roots had lower and less desirable swelling properties than gari from freshly harvested roots (Wenham, 1995).

Traditional methods of root storage after harvesting, such as burial in soil and piling in shades, are used for small quantities of cassava roots in order to increase its shelf life for 3 to 7 days (Westby, 2002).

0.1.8 CASSAVA PROCESSING

Although the cultivation of cassava requires low input of labour, post-harvest cassava processing is the most demanding of all root crops as it requires rapid handling and detoxification to make it edible. One of the major issues in the utilization of cassava is the high perishability of the tubers and its toxicity due to hydrogen cyanide. Deterioration by biochemical changes and microbial infestation starts within 2-3 days after uprooting. Long distances between production areas and processing sites are often a problem leading to considerable post-harvest losses (Balagopalan *et al*, 1988). Since there are no effective commercial storage methods available, it is necessary to process cassava into dry shelf-stable forms by reducing moisture content and thus lowering bulk and transportation costs (Falade and Akingbala 2010). Cassava processing improves palatability, increases shelf-life, facilitates transport and, most importantly, detoxifies cassava roots by removing cyanogens (Nweke, 1994; Westby, 2002; Nyirenda *et al.*, 2011). Cassava can be transformed to many products namely gari, *waterfufu*, cossettes, *bobolo*, *mintoumba*, *miondo* and starch (Tiky Mpondo, 1993). A flow diagram indicating the obtention of some of these products is shown below.

AMELIORATION OF THE LOCAL PRACTICE OF GARI PRODUCTION: CASE STUDY MUYUKA PRODUCTION ZONE

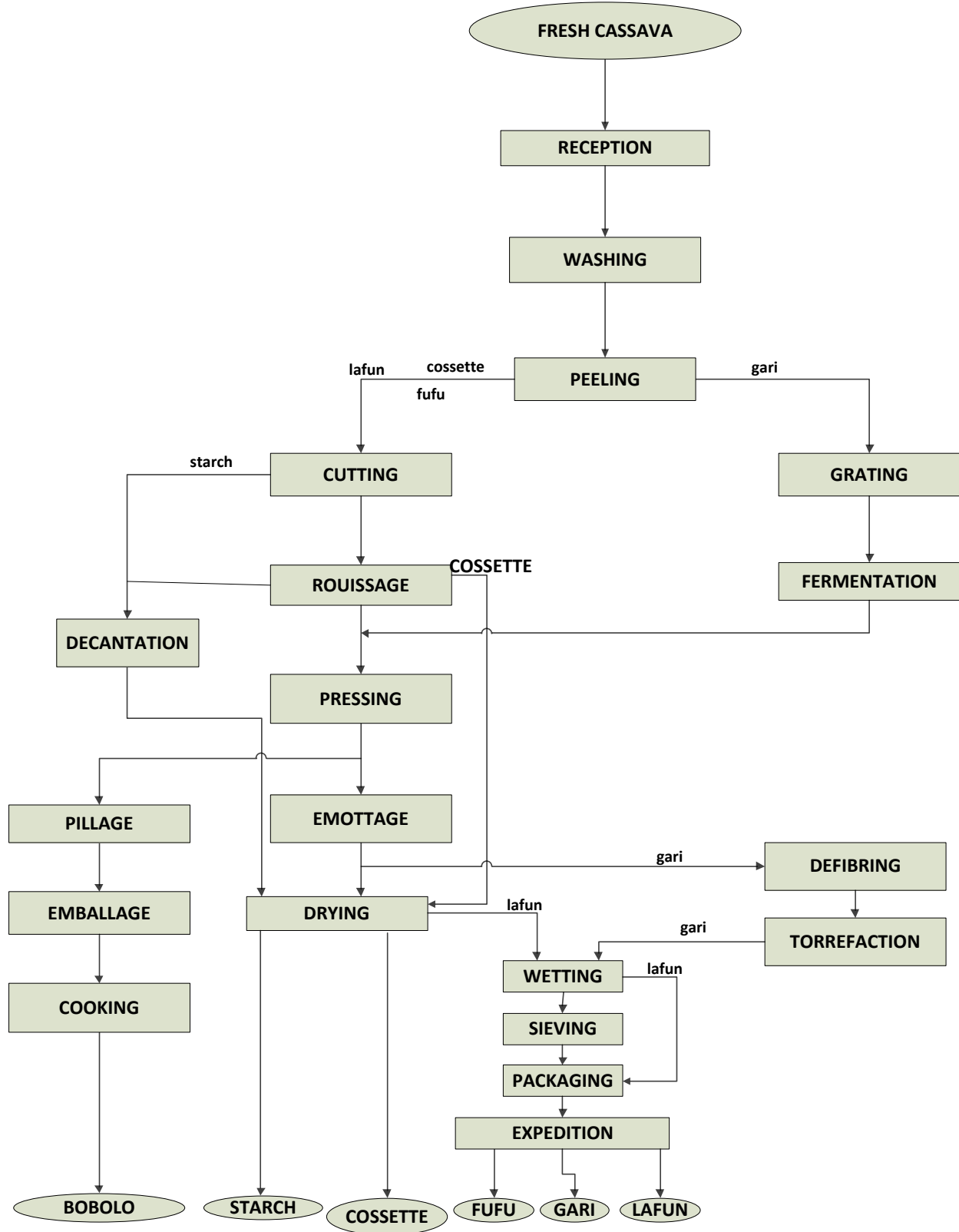

Figure 3: major cassava products and processing methods

AMELIORATION OF THE LOCAL PRACTICE OF GARI PRODUCTION: CASE STUDY MUYUKA PRODUCTION ZONE

Among these various products obtained from cassava, gari is the most popular accounting for 70% of the total cassava produced (Oduro *et al.*, 2000).

0.2 GARI

0.2.1 Introduction

Ernersto *et al.*, (2000) defined gari as a gritty, starchy staple with high energy content which is derived from cassava (*Manihot esculenta*, Crantz). According to IITA, (2005), it is the most popular staple food derived from cassava and it is a creamy-white, granular flour with a slightly fermented flavour and a slightly sour taste made from fermented, gelatinized and dried fresh cassava roots. It is consumed either soaked in cold water or stirred in boiling water to make a stiff paste and consumed with choice soup (Nweke *et al.*, 2002; Oti *et al.*, 2011). Gari can be yellow (if processes with red palm oil) or white (if not) (Oti *et al* 2011). Seventy percent (70%) of cassava processed as human food is gari (Oduro *et al*; 2000). Its wide consumption is attributed to its relatively long shelf life and its easy preparation as a meal (Oti *et al* 2011). Gari can differ from one type to another in terms of physical, chemical and sensory qualities. Its production can be carried out at small, medium or large scale (Sanni, 1990) involving the following unit operations: peeling, washing, grating, dewatering, sieving, frying/toasting (garifying), re-sieving and packaging (Elijah *et al.*, 2013). The processing of cassava to gari has up till now remain the main occupation of the rural woman who employes old and traditional techniques with little or no mechanisation (IFAD, 2007). Poor quality of manually produced Gari has been traced to problem associated with peeling, grating, milling, dewatering, sieving and roasting, which are all labour intensive (Adegun *et al.*, 2011).

0.2.2 Processing

Gari is produced at three levels: the small scale domestic level involving little or no mechanization; the medium scale commercial level where gari is produced using some machinery with maximum capacity of 1 ton per day and the large scale, highly mechanized industrial entity with a capacity of seven to eight tons per day (Sanni, 1990; Bruinsma *et al.*, 1985). In Nigeria, similar levels of processing are given as traditional, post traditional and modern production (Ngody *et al.*, 1980).

Arlène *et al.*, (2009) described the three techniques as: traditional technology with grating done by hand; traditional technology with mechanised grating; and semi-mechanical technology (vibrating sieve, grinder, gas dryer, etc.).

AMELIORATION OF THE LOCAL PRACTICE OF GARI PRODUCTION: CASE STUDY MUYUKA PRODUCTION ZONE

0.2.2.1 Unit operations

The flow diagram below shows the unit operations involved in gari production from fresh cassava roots (traditional method).

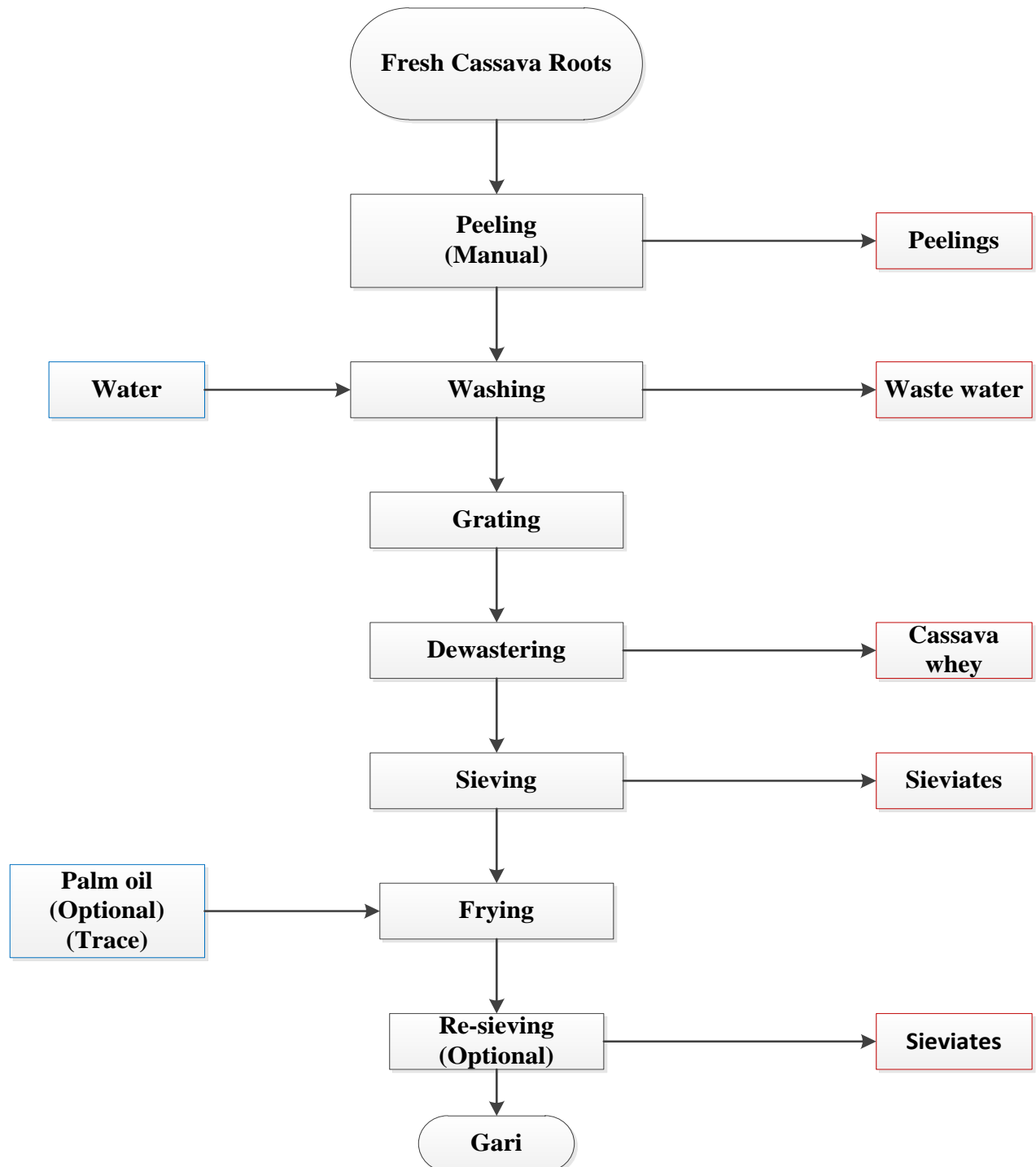

Figure 4: Traditionl process of gari production

AMELIORATION OF THE LOCAL PRACTICE OF GARI PRODUCTION: CASE STUDY MUYUKA PRODUCTION ZONE

0.2.2.1.1 Harvesting and sorting

Fresh cassava roots are harvested between the 10th and 11th months after planting since this is the period when the starch content, representing 80 % of the carbohydrates produced, reaches a peak, but this depends on the cassava varieties (Apea-Bah *et al.*, 2011). The roots are then sorted and the unhealthy indicating any signs of rots are discarded (Oti *et al.*, 2011).

0.2.2.1.2 Peeling

The peel of the “bitter” cassava variety was shown to contain on average 650 ppm and the pulp to contain 310 ppm total cyanide; the corresponding values for “sweet” varieties were 200 ppm and 38 ppm respectively. For a root composed of 15% peel with a total cyanide content of 950 mg/kg (fresh weight basis) and 35 mg/kg in the flesh, 83% of the total cyanide is removed by peeling (Bencini, 1991). At the village level, it is done manually using a knife but it is slow and labour intensive with little output. Many attempts has been made on the use of machines but much loss encountered, re-peeling areas of the tubers, which have already been peeled and leaving skin on other areas, particularly in depressions (FAO, 1991). In chemically peeling, hot solutions of sodium hydroxide (Lye) can be used to loosen the skin to facilitate later peeling, such as removal by water spray or scrubbing with brushes.

After peeling the roots are washed with clean water to remove any dirt, pieces of peelings, sand and then grated.

0.2.2.1.3 Grating

Grating breaks down the internal structure of the root, releasing linamarase that will decrease the cyanoglycoside content by about 95% by hydrolyzing the glucosides into HCN (Falade and Akingbala, 2008). Since HCN is soluble in water, its amount is reduced by traditional detoxification methods like de-watering (Dziedzoave *et al.*, 2006). It is also done in order to expose the maximum surface (i.e. increase surface area) of the starchy flesh and encourage a rapid water loss during pressing and for fermentation to take place. In this unit operation, washed roots are then grated properly in clean stainless steel grater to obtain uniformly smooth mash (Oti *et al.*, 2011). The grated mash must be uniformly smooth without lumps (Oti., 2011). The smoothness of the mash determines the quality, yield and market value of the finished gari (Oti *et al.*, 2011).

AMELIORATION OF THE LOCAL PRACTICE OF GARI PRODUCTION: CASE STUDY MUYUKA PRODUCTION ZONE

0.2.2.1.4 Fermentation

The grated cassava mash was then put into clean sack(s) and tied (Oti *et al.*, 2011). It then allowed to stand in a fermenting trough for 2-4 days (Oti *et al.*, 2011). Sacks are arranged in such a way that there is no contact with sand or dirt that can contaminate the mash (Oti *et al.*, 2011). Free sipping of water from the sacks should be ensured (Oti *et al.*, 2011). There are variations in fermentation period within and among countries (Oti *et al.*, 2011). However, fermentation should not be less than 2 days to allow development of the characteristic sour taste and flavor of gari (Oti *et al.*, 2011). The main type of fermentation in cassava is lactic acid fermentation carried out by lactic acid bacteria (Oti *et al.*, 2011). Which ferment the starch into lactic acid given gari and other fermented products its characteristic taste and flavor (Oti *et al.*, 2011). Fermentation is also important in cassava processing based on its ability to reduce the cyanogenic glucosides to relatively insignificant levels (Oti *et al.*, 2011). It has been found that fermentation is a period or process of detoxification, which occurs in two stages:

The bacterium, *Corynebacterium manihoti*, starts the fermentation process by attacking the starch present with the production of lactic and formic acids. This results in the lowering of the pH, which produces favourable conditions for the endogenous enzyme linamarase to hydrolyse linamarin and laurostrolin into gaseous hydrogen cyanide resulting in detoxification. The lowered pH also produces favourable conditions for the growth of the fungus *Geotrichum candida* that produces a variety of aldehydes and which contributes to the characteristic flavour and aroma of gari (Collared and Levi, 1959; Jones *et al.*, 1993). But this can vary depending on the geographical region concerned since microorganisms are specific to some geographical locations. After fermentation, the pressing is carried out.

0.2.2.1.5 Pressing

This is carried out to remove as much moisture as possible. This operation unit is completed when water is no longer dripping from the sacks (Oti *et al.*, 2011). If dewatering is not complete, there would be lumps during toasting which reduces quality and yield of gari (Oti *et al.*, 2011). The pressing time depends on the efficiency of the press and moisture content of the mash (Oti *et al.*, 2011). After pressing, cake breaking is then carried out done in order to remove the large lumps and fibre (from the central vascular strands) and to obtain a homogenous product (Oti *et al.*, 2011).

AMELIORATION OF THE LOCAL PRACTICE OF GARI PRODUCTION: CASE STUDY MUYUKA PRODUCTION ZONE

This brings about a more uniform roasting of individual particles during the frying operation since smaller particles took less time and less energy in roasting (reference). When cake breaking is achieved, one of the must step which determine and has an influence in the quality of gari is roasting. (Wilhemina *et al.*, 2009)

0.2.2.1.6 Roasting

Gari frying is the most critical unit operation in the processing of cassava into gari (Gbasouzor and Gbasouzor, 2012). It is also a combination of simultaneous cooking and drying processes (Gbasouzor and Gbasouzor, 2012). The moisture content of dewatered and sieved cassava mash is between 50 to 65% which has to be reduced to 12% after the frying operation. During this operation, the product is first cooked (gelatinised) with the moisture in it and then dehydrated. If the moisture content of the mash is too high, it will result to large lumps of gari and similarly if it is too high, it will result in producing gari with white color instead of cream white with no characteristic flavor of gari. This may take 20-30 mins depending on the heat source and quantity of sifted cake with the moisture content of the final product reduced to about 18%. (Oti *et al.*, 2011; Gbasouzor and Gbasouzor, 2012). It is then left to cool and dry in a cool dry shade until the moisture content is reduced to 12%. During this process the mash is continually stirred in order keep the material moving to prevent it from burning until frying was completed when it reaches a temperature of about 80° to 85°C (Elijah *et al.*, 2012). The finished product (gari) is usually recognized from the color change from white to cream (for non-palm oil fortified gari) and crispy hand feel of the grains/particles (Oti *et al.*, 2011). Optionally, trace quantities of oil palm is added during frying, depending on the desired colour (white or red) of the gari. Additionally, the oil prevents burning during frying it also helps to detoxify residual cyanide in the gari (Elijah *et al.*, 2012).

The toasted gari is then collected into a clean basin and spread on a raised platform lined with clean polythene material or white cloth to cool to room temperature, sieve to obtain granules of uniform size and then packed in desired quantities in polythene bags and/or sacks, seal or stitch as appropriate (Oti *et al.*, 2011).

AMELIORATION OF THE LOCAL PRACTICE OF GARI PRODUCTION: CASE STUDY MUYUKA PRODUCTION ZONE

0.2.3 Gari processing Scales or levels

As mentioned above, it occurs at three levels: small, medium or large scale, equally classified as traditional, post traditional and modern production (Ngody *et al.*, 1980; Sanni, 1990).

0.2.3.1 Traditional Method of Production

This involves gari production with little or no mechanization and no valorization of by products. The operations is as shown in figure 2. The level is characterized by the fact that fermentation and dewatering are a single operation.

0.2.3.2 Post Traditional Method

In Ghana, post-traditional manufacture of fermented cassava products is also known to exist (Bruinsma *et al*, 1985). In this improved technology, fermentation and dewatering are separate processes. Liquid expressed during dewatering acts as a starter culture and accelerates the fermentation for subsequent material (Bruinsma and *al*, 1985). Laryea *et al*, (1980) reported that the exudates from cassava dough which has undergone more than 6 hours of fermentation before pressing can also be used to inoculate a batch of freshly grated cassava at a rate of 1 kg liquor to 5 kg mash. This reduces the traditional fermentation period from about 60-72 hours to 30-36 hours. Owuamanam *et al.* (2011) studied the impact of seeding fermenting cassava mash with preferment liquor, and fermenting at different temperature and time regimes. This resulted in a residual cyanide level of 8.36 mg/kg in gari when preferment liquor concentration of 20% was used, however, it had some short comings in terms of the flavor of the resulting gari.

In Nigeria, the post-traditional production (**annex 1**), has a capacity of up to 1 ton of gari per day. As in the tradition, a peeling machine has been introduced and it is only useful for peeling smaller roots. As in the tradition, a peeling machine has been introduced and it is only useful for peeling smaller roots. Roll rasps do grating and fermentation takes about 2-3 days and is carried out in aluminium or plastic vats or in polypropylene bags. Pressed liquid from earlier batches is added to hasten the fermentation. Screw presses are used to dewater the mash. The pulp is dewatered to about fifty percent (w/w) moisture in 1 hour. The pulp is sifted by hand-operated screen. By means of a mechanised gari roaster, the pulp is dried, with an output of 65 kg gari per hour (Ngody, 1980).

0.2.3.3 Modern Technology or Method of Production

The mechanisation of all unit operations and by the use of conveyor belts and pneumatic conveyors characterises the modern process of gari production (**annex 2**). The fermentation time is reduced by inoculation with starter. Culture obtained from earlier batches, while roasting and drying are done in separate machines (Bruinsma *et al*, 1985). A rotating abrasive drum is used in peeling the cassava. However, the mechanical peeling gives irregular results and leads to relatively high peeling loss. Peels and washing water are flushed out of the factory and separated by screening or a settling pit. The peeled roots are disintegrated in a hammer mill and the mash is mixed with fermentation liquor from previous batch. Fermentation takes place in woven polypropylene bags placed in large vats (1 ton per vat) and lasts 3-4 days. Dewatering is done in a horizontal hydraulic press. A lump breaker breaks up the mash and passed over a screen, which removes coarse particles and fibres. A constant rate feeder then feeds the material to the specially developed gari roaster. The mash is gelatinised in a rotating cascade drum drier to about 8% (w/w) moisture content. After drying, the product is milled and sieved to obtain the required particle size range.

Figures of the post traditional basic process for gari manufacture (From Cook *et al.*, 1975; Williams, 1975) and the modern processing technology are shown in **annex 1 and 2**.

0.3 Types of gari

Although gari is defined with emphasis being laid on using cassava as the raw material used, other roots and tubers have been in the past years used to produce gari.

In Cameroon and other West African Countries, gari is only distinguished based on whether it is white (non-fortified with red oil) or yellow (fortified with red oil). This fortification goes a long way to bring about price differential of the product in the market.

In other African countries like Benin We also find several varieties of gari obtained through some technological modifications to the manufacturing process. Gari types obtained differ in taste, color, size or the moisture content (Nago, 1995; Akotègnon, 2000). Ordinary and enriched gari has also been identified (Akotègnon, 2000; Dziedzoave *et al*, 1996).

0.4 Production and Consumption of gari

In West Africa, it is the most consumed and traded of all food products made from cassava roots (Oti *et al.*, 2011).

AMELIORATION OF THE LOCAL PRACTICE OF GARI PRODUCTION: CASE STUDY MUYUKA PRODUCTION ZONE

Seventy percent (70%) of cassava processed as human food is gari (Oduro *et al.*, 2000). Its wide consumption is attributed to its relatively long shelf life and its easy preparation as a meal (Oti *et al.*, 2011). The acceptance and popularity of gari in urban and rural areas of west and Central Africa is attributed to its ability to store well, its convenience and ready-to-eat form (Flach, 1990). Gari is consumed by all segments of the population especially women and children; it is thus a food for home food security (CFD, 1998). Results from studies conducted by Njukwe *et al.*, (2014) shows that gari has a 72.50% score in among the major processed products in Cameroon after fufu which had a 95.00% score.

0.5 Criteria of quality gari

Criteria on which to judge gari quality are based on color, taste, size of the grains, moisture content, swelling capacity and perhaps by its HCN content. Properly roasted gari should be creamy in color but not whitish or translucent, for this would indicate partial roasting. The taste of the gari should be sharp (sour), but not too sharp. For example gari that tingles the palate along the hinges of the jaw is deemed too sharp. In some markets a noticeable difference in taste translates into a price difference of as much as 30 percent by volume. The third quality characteristic is size of the grain. Gari can be as big eyes and small eyes. According to processors in Ghana, big eye gari when reconstituted do not absorb water completely, and therefore yield a non-uniform gari. On the other hand, the small grains which soak up water too fast. Consequently, the preferred grain size is somewhere between the two ; gariyano describes the preferred medium size grain.

On the basis of particle size determined by use of test sieves complying with ISO 2591-1, gari can be classified as follows:

AMELIORATION OF THE LOCAL PRACTICE OF GARI PRODUCTION: CASE STUDY MUYUKA PRODUCTION ZONE

Table 6: gari classification with respect to particle sizes

Class	Requirement
Extra-fine grain garri	Garri of which not less than 80% of the weight shall pass easily through a sieve with aperture below 355 microns
Fin grain garri	This is garri of which not less than 80% of the weight shall easily pass through a sieve with aperture 1000 microns but of which less than 80% of weight shall easily pass through a sieve with aperture 355 microns
Coars (medium) grain garri	This is garri of which not less than 80% of the weight shall easily pass through a sieve with aperture 1.40mm but of which less than 80% of weight shall easily pass through a sieve with aperture 1.00m
Extra coarse grain garri	This is garri of which not more than 20% of the weight shall easily pass through a sieve with aperture 1.40mm
Unclassified garri	This is garri which has not been classified by the sieve method to determine its category according to grain size

Table 7 below shows the compositional requirements for gari.

Table 7: gari composition

Parameters	Requirements
Moisture content, %,by mass, max	7.0
Total acidity, determined as lactic acid	0.6 – 1.0%
Crude fibre, % m/m, max	2.0
Sodium chloride (NaCl) on dry weight basis, %, max	2.0
Total cyanide content, mg/kg, max	20.0
Total ash, % m/m, max	1.50
Acid insoluble ash,%, by mass, max	0.2

(CODEX STAN 151-1985)

AMELIORATION OF THE LOCAL PRACTICE OF GARI PRODUCTION: CASE STUDY MUYUKA PRODUCTION ZONE

The general structure of this present study on gari is as shown below.

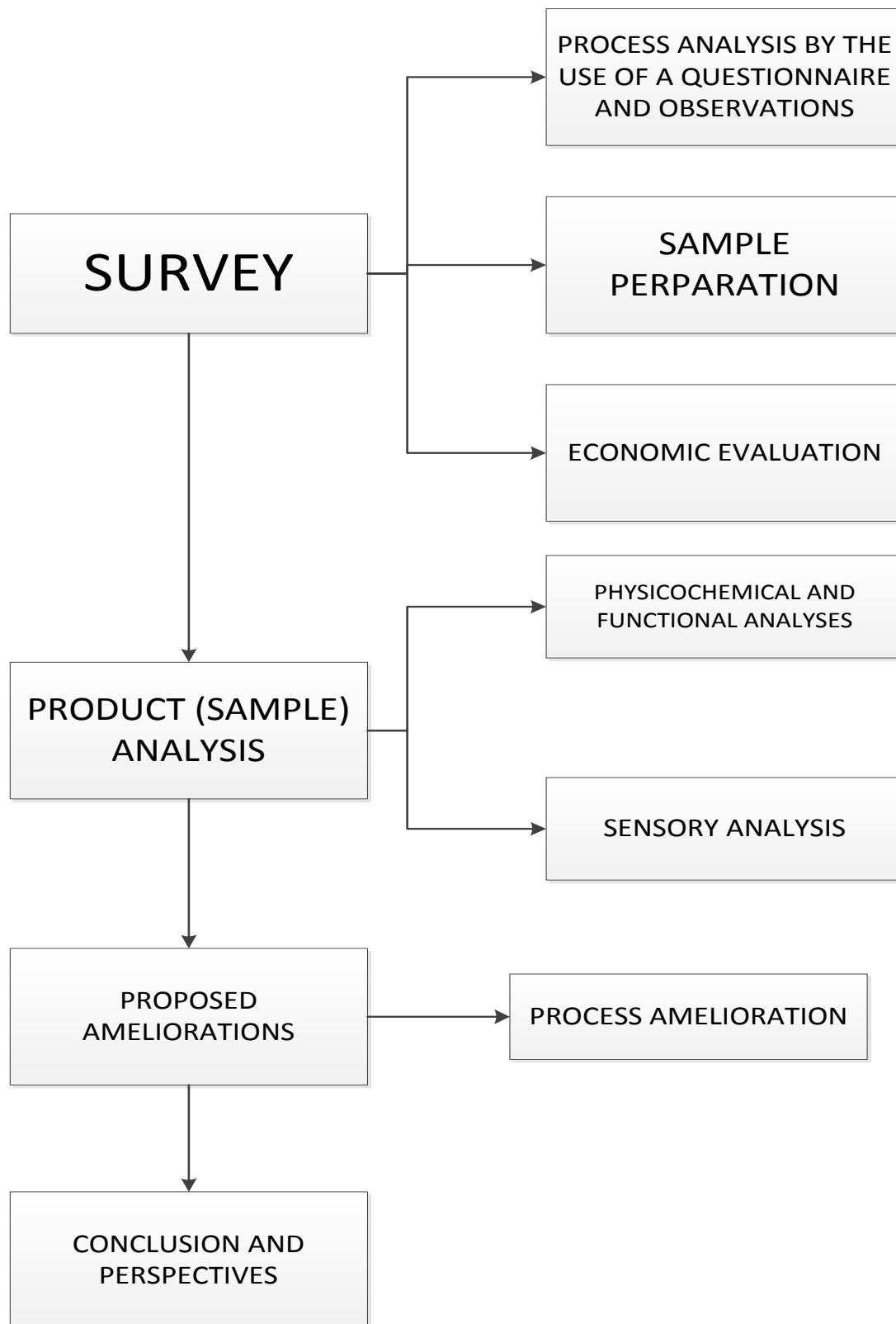

Figure 5: general structure of present work

AMELIORATION OF THE LOCAL PRACTICE OF GARI PRODUCTION: CASE STUDY MUYUKA PRODUCTION ZONE

DIAGNOSTIC STUDY ON GARI PRODUCTION: CASE STUDY MUYUKA

I-INTRODUCTION

The Cameroonian economy is predominantly agrarian, where agriculture and exploitation of natural resources remain the driving force of the country's economy. Divers crops are cultivated across the different agro-ecologies of the country with roots and tubers being the most cultivated as in all Central African countries upon which a greater part of the population depend for their livelihood. Cassava products are components of basic food intake for 7 to 8 million people in Cameroon, mostly living in the 8 southern Regions (Nord and Extreme-Nord being exceptions), and cover around 8 percent of daily nutritional needs, lying just below plantain (9.8 percent) in the group of starchy food crops (FAO, 2009).

At the regional level, cassava is the first crop in the category of roots and tubers that is produced in a large scale in Central Africa. It is now a major component in fighting hunger and the food crisis (IITA, 1989). Cassava being the main starchy staple in Cameroon with 80% of rural and urban households consuming cassava and cassava derived products on a daily basis, has increased the demand for cassava which has led to increased prices and an increase in production exceeding the previous traditional subsistence systems with the annual production estimated today at 3 million tons. Cassava is highly climate and soil-tolerant regarding its yield performance and thrives in growing conditions in agro-ecological areas and seasons which would not otherwise fit the physiological requirements of other crops. Cassava does not require large amounts of inputs and fertilizers and is highly suitable for processing, which compensates for its high perishability as a crop. Caloric yields of cassava by land unit and growing time unit are very high and over perform those of other cereals and tubers. Regarding dry matter yields by land unit, cassava dominates the top ten tropical crops.

Among all the varieties of cassava products found in the country, about 70% of the fresh tubers is transformed into gari (Njukwe *et al.*, 2014). This is because of the following reasons: it is easy to store (long shelf life which is as result of its low moisture content), fast to cook, ease of transport and also gari is a convenient food well suited for a busy urban lifestyle.

AMELIORATION OF THE LOCAL PRACTICE OF GARI PRODUCTION: CASE STUDY MUYUKA PRODUCTION ZONE

OBJECTIVES

The first part of this work was on a diagnostic study on the local practice of gari production carried out in Muyuka, a small agricultural town in the South West Region of Cameroon which according to PNDRT report 2010 is a major gari producing zone in the country:

- To bring out the market requirement and major destination of gari produced
- Carry out a production trial and
- to do an economic evaluation of the activity or sector.

II-MATERIAL AND METHODS

II-1-Study area

Muyuka is found in the South West Region of Cameroon, in the Fako Division about 5km from Buea. It is a typical agricultural zone with farming being the main occupation of the people. The main cash crops cultivated are cocoa, coffee and rubber latex which belong to the Cameroon Development Cooperation (CDC) and the main staples are cassava, plantain and cocoyam. The major products of cassava in this area are gari, fufu, and the minor products are bobolo, starch.

II-2-Diagnosis

This diagnostic study or survey consisted of a field work on the practice of gari production, interview sessions with the producers, all these guided by the use of a structured questionnaire. In this survey, 32 gari producers were interviewed.

II-2-1-Questionnaire

This diagnostic study was carried out by the use of a structured questionnaire in an interview session with the gari producers from the month of June to July 2014 and it consisted of the following group of questions:

- Identification: this was aimed at bringing out the socioeconomic and even political status of respondent. It consisted of items like age, nationality, marital status, level of education, number of years of experience in gari production and position in the production unit.
- Primary material: this part had questions on the origin, age, varieties, and yield of the raw material used by producers.

AMELIORATION OF THE LOCAL PRACTICE OF GARI PRODUCTION: CASE STUDY MUYUKA PRODUCTION ZONE

➤ Transformation process: here we were supposed to bring out the various unit operations as carried out by each producer.

➤ Yield: where information on the highest and lowest amount of gari and cassava transformed per production was given. And information about gari yield too was obtained.

➤ Questions relating to the quality, critical operations, difficult operations and some supplementary questions on equipment and profitability was also obtained. Acopy of the questionnaire is given in annex 10.

II-3-Production trial

The second part of the survey was sample preparation in which 3 cassava varieties (Owe stick, Kumba stick, Var. 8017 of IRAD), commonly used in the area were used at 100% to produce gari. Gari was produced by employing the following unit operations: peeling, washing, grating, fermentation, pressing, fragmentation, frying and cooling.

II-3-1-Specificity of production

The resulting mashes after grating were pressed using the stick press and mechanical press and the fermentation period was varied from 0-3 days. But all the other operations were the same. This gave an experimental design of 24. They were then packaged in polyethene bags and transported to ENSAI, University of Ngaoundere for physicochemical and sensory analyses as shown in the figure below.

II-4-Economic Evaluation

This was done using economic theories of evaluating the cost of production, profit, differential cost evaluation using indirect and direct charges analysis.

II-5 Data analysis

All data obtained from the survey were analysed by a statistical software Sphinx plus² – Edition lexic-V5.

AMELIORATION OF THE LOCAL PRACTICE OF GARI PRODUCTION: CASE STUDY MUYUKA PRODUCTION ZONE

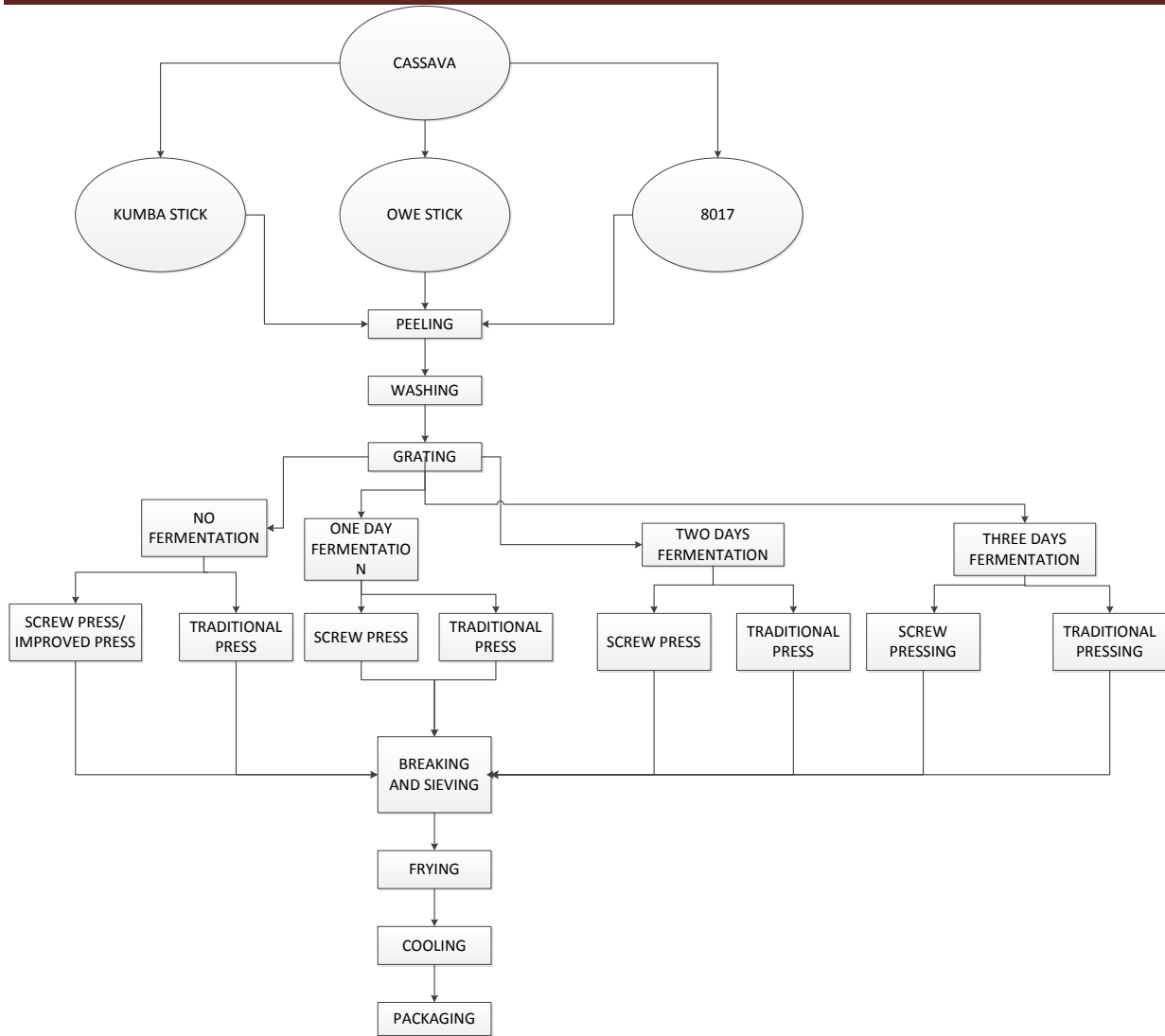

Figure 6: sample preparation

N.B. The three varieties of cassava were prepared separately following the unit operations as shown in the figure and this gave us twenty four different gari samples.

AMELIORATION OF THE LOCAL PRACTICE OF GARI PRODUCTION: CASE STUDY MUYUKA PRODUCTION ZONE

II.6 RESULTS AND DISCUSSION

II.6.1 Major actors in gari production

Results obtained indicated that women are the major actors involved in gari production since 87.5% of the respondents were females. This observation just confirms the remarks made by Njukwe et al., 2014 whose results indicated that 68.75% of women are involved in cassava processing and marketing activities. And also age wise, gari production is mostly carried out by age people generally between the age of 40-60 as this gave 65.6% of the total. This can be explained by the fact that in a family the parents are the ones providing the food and trying to meet the needs of every member this obviously will lead them into this kind of activity. This also confirms why 71% of the actors are married. This is as shown below.

Table 8: Gender, age and marital status of actors in the gari sector

parameter	variable	frequency	total
gender	masculine	12.5%	100%
	feminine	87.5%	
age	<20	3.10%	100%
	20-30	6.30%	
	30-40	25.00%	
	40-60	65.60%	
	>60	0.00%	
Marital status	Bachelor/Spinster	18.80%	100%
	married	71.90%	
	divorced	0.00%	
	widow/widower	9.40%	
	couple	0.00%	

In terms of the level of education, majority of the actors are First School Leaving Certificate holders making up 65.6%. Similar results have been obtained by Chukwuji *et al.*, (2007).

The type of production unit operated by this producers shows that all of them are peasant producers (artisanal de type familial).

AMELIORATION OF THE LOCAL PRACTICE OF GARI PRODUCTION: CASE STUDY MUYUKA PRODUCTION ZONE

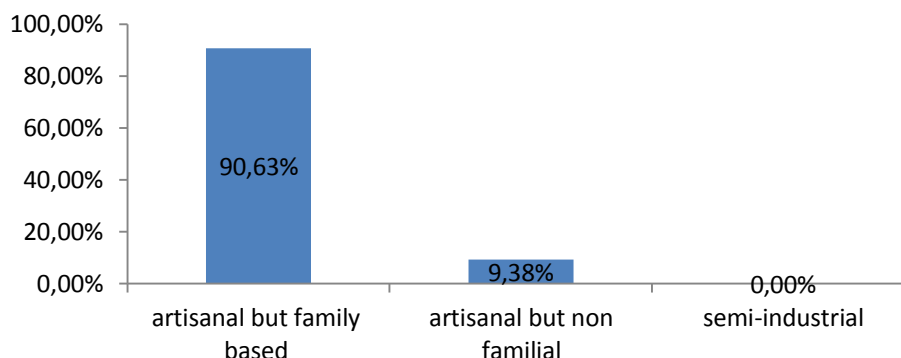

Figure 7: nature of gari processing units

This result is in relation to the observation made by Njukwe *et al.*, (2014) that apart from baton that was processed among groups, other products were reported at individual and household levels (gari). From response gotten during this survey, not only the family members are involved in processing as help can come from any other person in the quarter as volunteers.

Sometimes a family can also decide to hire a laborer for a day job in order to facilitate production. And since it is a family business carried out at house hold it was also reported that at household level, production is characterized by small farm size and rely on family labour

for processing, in order to meet family food requirements and generate incomes (Njukwe *et al.*, 2014) hence 78% of respondents were owners of the production units with 37.50% of them having 5-10 years of experience in the activity. With 90% of them processing in order to supplement their families and for commercial venture.

AMELIORATION OF THE LOCAL PRACTICE OF GARI PRODUCTION: CASE STUDY MUYUKA PRODUCTION ZONE

II.6.2 Primary material

All of the producers of gari use fresh cassava roots harvested on the same day as shown.

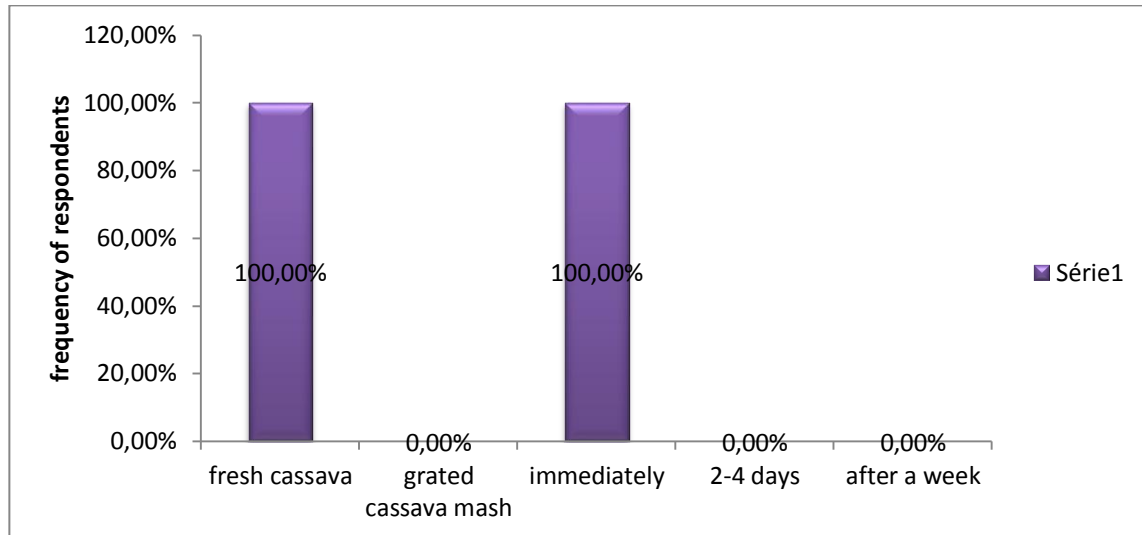

Figure 8: nature of raw material and time lapse before processing

The practice whereby the producers transform freshly harvested roots on the same day is a very healthy one since Ruiz, 1991 reported that storage of roots for more than 36 hours after harvest alters the color and flavor of the resulting starch and in gari production, Wenham reported that the resulting gari may have less desirable swelling properties than the one made from freshly harvested roots. Result shows that nobody uses already prepared mash by some other person in production. These fresh roots either come from the market or from auto production but majority is from auto production as shown with producers having preference over different varieties for various reasons as shown on the next figure.

AMELIORATION OF THE LOCAL PRACTICE OF GARI PRODUCTION: CASE STUDY MUYUKA PRODUCTION ZONE

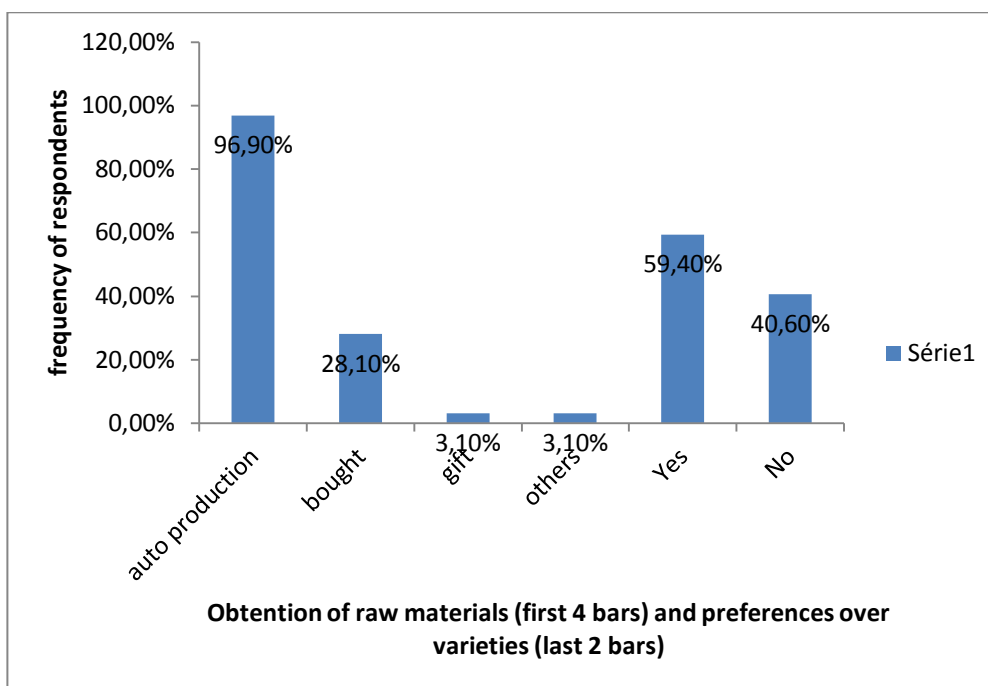

Figure 9: obtention of raw material

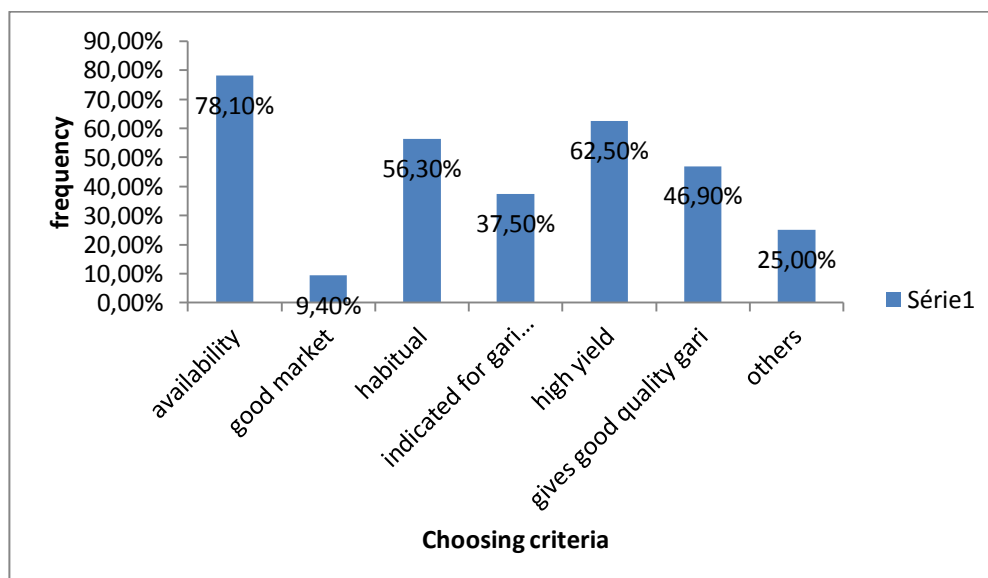

Figure 10: reason for preferences over varieties

Results show that the age of cassava used by majority of the producers varies between 10-18 months having about 81% and this is good practice since it has been shown that this is the period when the starch contents in the roots is at its peak. Although it was not analysed statistically, from personal observations the use of kumba stick a local variety name is the most dominant in gari production in the zone of study.

AMELIORATION OF THE LOCAL PRACTICE OF GARI PRODUCTION: CASE STUDY MUYUKA PRODUCTION ZONE

II.6.3 Transformation process

The order of steps as used by majority of the producers is shown in the process flow chart below. Irrespective of the producer and the scale of production, all the steps are the same. The only difference was noticed only among those who buy directly from the market and those who go and harvest from their own personal farm (auto production) the percentages were 9.40% for those who buy and 90.60% for those who harvest.

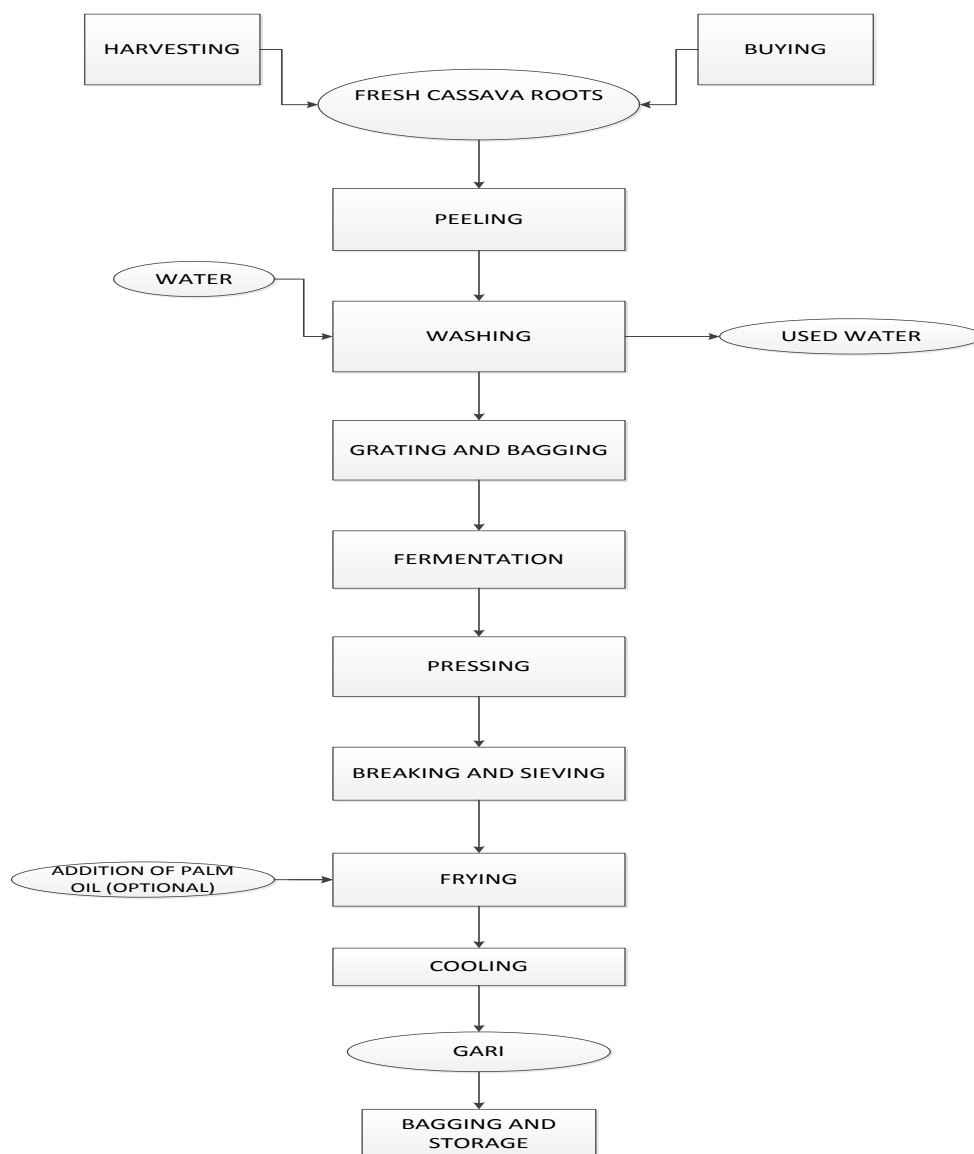

Figure 11: process flow diagram of all processors

AMELIORATION OF THE LOCAL PRACTICE OF GARI PRODUCTION: CASE STUDY MUYUKA PRODUCTION ZONE

II.6.4 Transformation capacity/ Mass yield

From the response gotten we were able to classify the producers with respect to the smallest and highest amount of cassava transformed and gari obtained respectively per production and this is given as shown below.

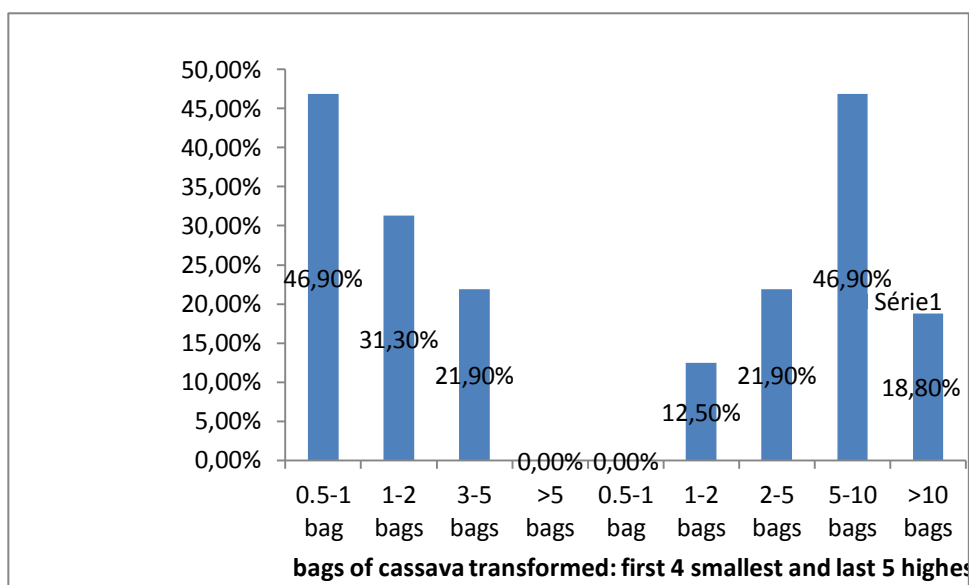

Figure 12: Quantity of cassava transformed by processors

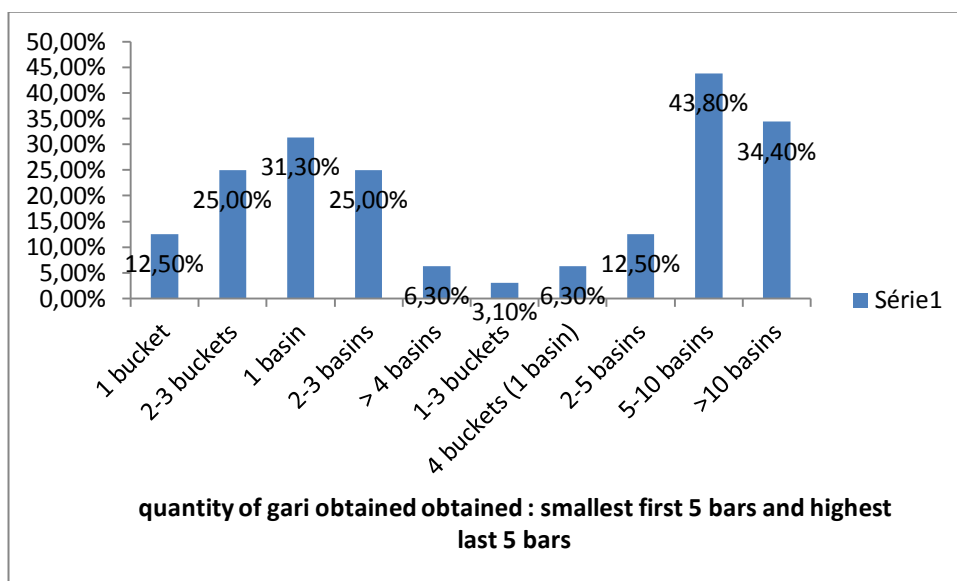

Figure 13: amount of gari obtained

AMELIORATION OF THE LOCAL PRACTICE OF GARI PRODUCTION: CASE STUDY MUYUKA PRODUCTION ZONE

During the survey some quantitative measurements were made in order to determine the conversion rate of some varieties of cassava used in this area.

For white cassava or Kumba stick as locally known, we started with 95kg of fresh roots and the peeled roots gave 76 kg giving a peeling yield of 78.35%, washing yield gave 77.84%. The quantity of gari obtained was 19.5 kg giving a conversion rate or yield of 20.10%.

For variety 8017

Initial weight=92 kg

Weight after peeling=68.5 kg

Peeling yield= $68.5/92*100=74.46\%$

It was then weighed after washing and the washing yield was 73.91%.

The amount of gari that was obtained was 10.5 kg (ignoring losses) this gave a gari yield or conversion rate of $(10.5/92)*100=11.41\%$.

The third variety of cassava used was Owe stick and we started with 93.5 kg of fresh roots. After peeling we had 76 kg this gave a peeling yield of 81.28%. After washing we obtained 76 kg still implying that peeling yield is equal to washing yield. The amount of fried gari obtained was 16.5kg giving a gari yield of 17.65%.

The results shows that the gari yield vary from one variety of cassava. Among the three varieties used, var 8017 presents the lowest yield. This yield is far below the recommended limit of gari yield which is btween 15-20 %. One of the varieties even had a conservation rate of 20.01.

0.5.1 Duration of unit Operations

The total time spent on each unit operation was variable and this depended on the quantity of gari to produce, number of workers. The unit operations that were critical here were the fermentation time and frying time. For all the 32 respondents that were concerned for this survey with the variations in quantity produced and number of persons, the average value for the fermentation time was 36.41 hours which corresponds to about 1.5 days approximately. This number of days for fermentation i s small compared to the number recommended by Oti *et al.*, (2012) in the production of high quality gari.

AMELIORATION OF THE LOCAL PRACTICE OF GARI PRODUCTION: CASE STUDY MUYUKA PRODUCTION ZONE

The average frying time was 31.41 hours corresponding to 1.3days. The average smallest amount of gari produced for all 32 producers was 1 basin meaning that more than 24 hours is needed to fry a basin of gari making this operation the most stressful in gari processing. This is in line with the observation of 65% of the total time in gari processing could be spent on peeling and 25 percent in roasting (William, 1979). The sitting posture and heat dissipated during brings alot of discomfort.

With respect to the most difficult operations on gari processing, a great number of producers did mention frying and peeling. This is partly due to the long time spent in carrying out these unit operations and on the other hand the health hazards relating to frying. This brings out some of the constraints faced by gari producers like low productivity which due the low capacity of the fryer , few grating machines available since they dont do hand grating any more. The bad nature of farm roads also make it difficult to transport the cassava for processing. Also rupture in the availability of raw material and cassava rot are other constraints experinced by producers and finally low returns due to constant price fluctuation is also faced by producers. Davies *et al.*, (2008) cited some of these points as major problems faced by cassava processors in Oyo state in Nigeria. These same remarks have been made by Gbasouzor and Maduabum, (2012) on the inconveniences of village frying techniques.

II.6.6 Quality of gari respect to market requirements

The criteria for evaluation of good quality gari by the producers is as shown in the bar chart below. This is in relation to what is demanded in the market.

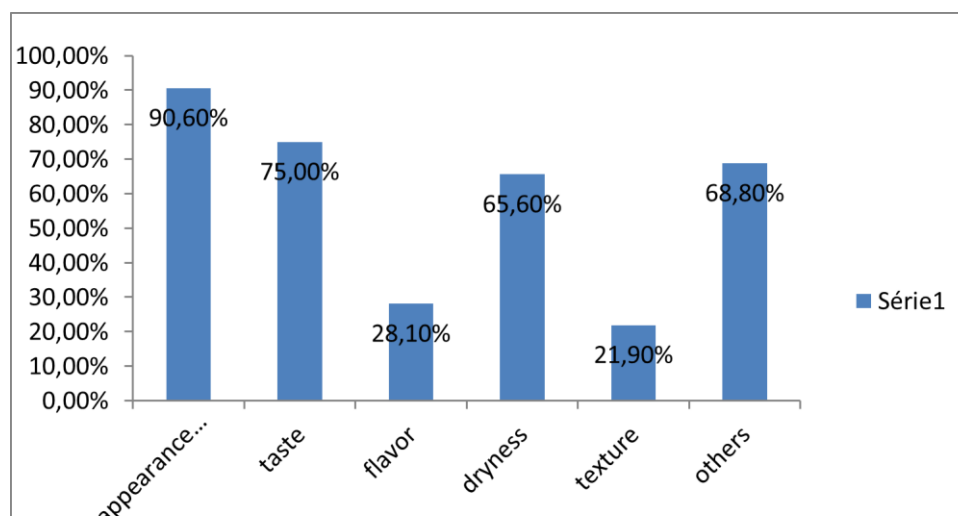

Figure 14: Quality parameters of processors

AMELIORATION OF THE LOCAL PRACTICE OF GARI PRODUCTION: CASE STUDY MUYUKA PRODUCTION ZONE

This shows that color of gari, taste, and other criteria like weight when carried on the hand, not being too dusty are the main criteria for evaluation.

II-7- Supplementary Questions

Other supplementary questions like sources of labour, income for financing production, and profitability of the activity were also posed to the producers and their results are as shown by the following bar charts.

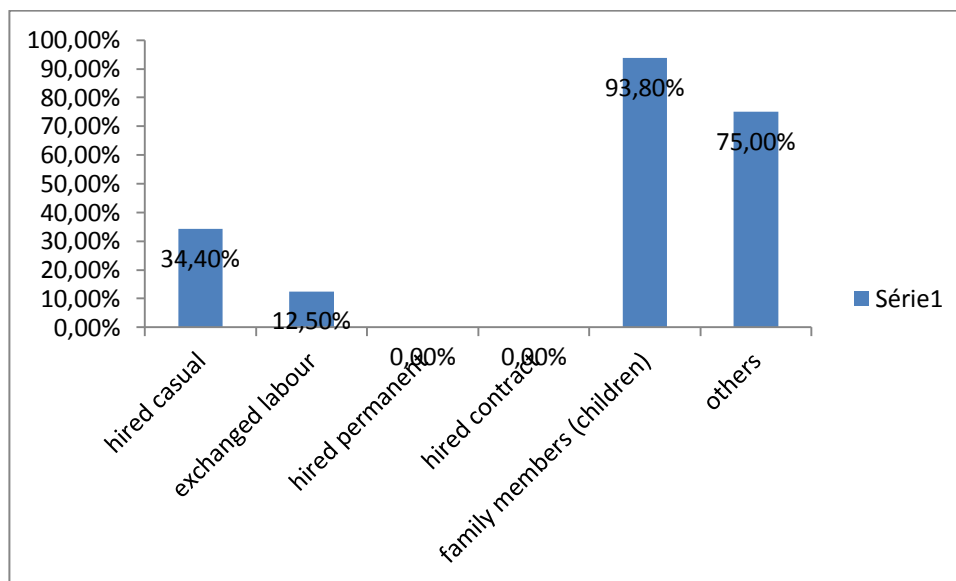

Figure 15: labor sources

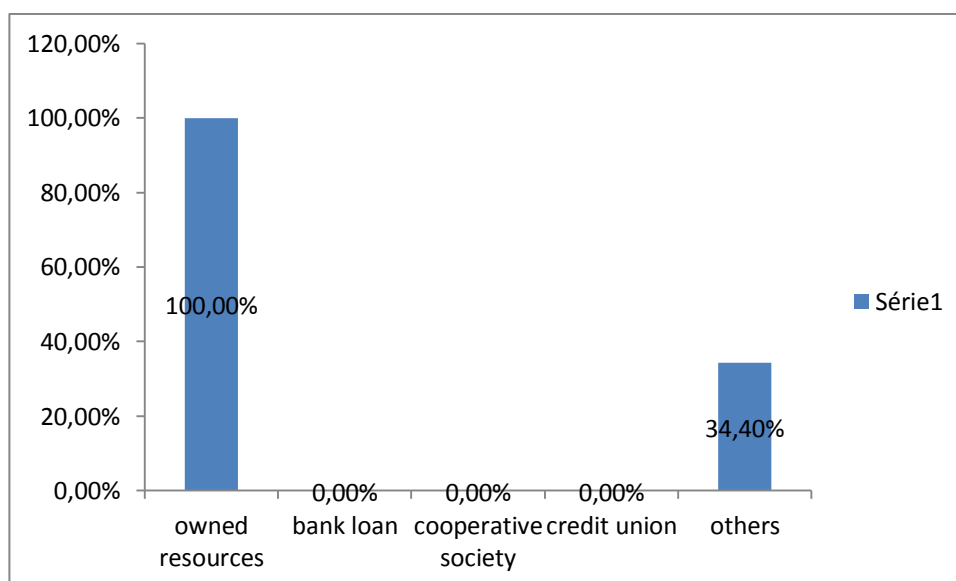

Figure 16: financing of production

AMELIORATION OF THE LOCAL PRACTICE OF GARI PRODUCTION: CASE STUDY MUYUKA PRODUCTION ZONE

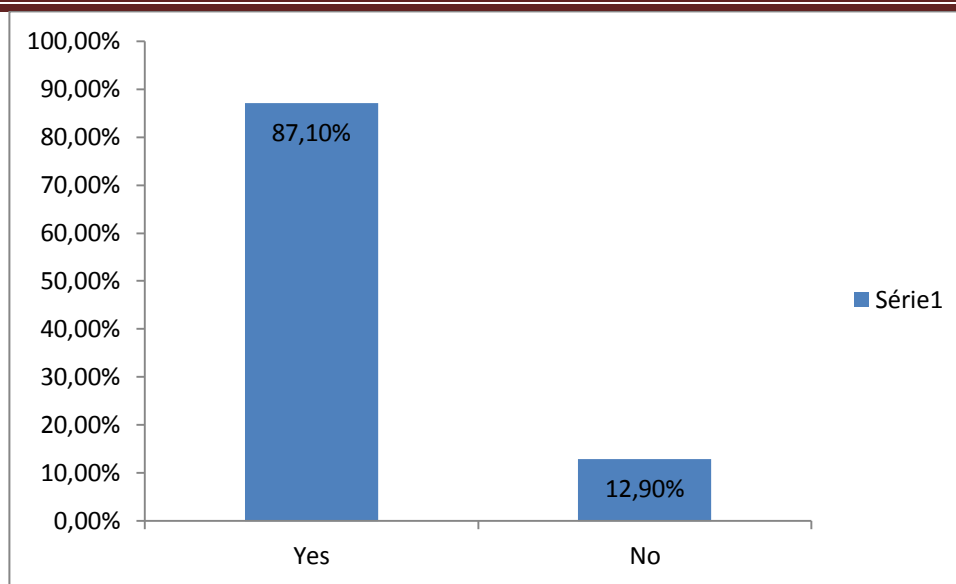

Figure 17: profitability as assessed by producers

From this responses about the profitability of gari production most of those who said yes did not take into account the cost of the items that they provide by themselves. This means they into consideribg as cost only what they buy during production. In the second part of this survey which was on evaluating the profitability of this sector, we try to regroup all the charges and even went ahead paying each worker to see whether really this sector is profitable.

II.7 ECONOMIC EVALUATION

In Muyuka like in other parts of Cameroon, gari production is still carried out strickly on household basis just involving the family members or in some cases volunteers who come in as helpers.

In this section of the work we are going to be evaluating the entire activity starting from what is put in as investments and what comes out as profit. In order to carry out this calculations, we assume that the amount of gari produced or quantity of cassava transformed is a constant for each batch of production. We also assume that production is done twice per week giving 96 productions per year (production cycle).

AMELIORATION OF THE LOCAL PRACTICE OF GARI PRODUCTION: CASE
STUDY MUYUKA PRODUCTION ZONE

II.7.1 Calculation of Working Capital

Table 9: Cost of raw Material

Raw material	Quantity/kg	Unit price/Fcfa	cost/production	cost per year/Fcfa
Cassava roots (cost price and charges)	235	65	15275	1466400
total	235	65	15275	1466400

Table 10: Calculation of depreciation cost

items	quantity	unit price	cost	life span/years	depreciation cost/year in Fcfa
knives	4	700	2800	3	933.3
basins for washing	2	4500	9000	5	1800.0
basins for carrying water	2	1500	3000	5	600.0
basins for containing gari	1	5000	5000	10	500.0
sacks	5	1000	5000	3	1666.7
sieve	1	3000	3000	4	750.0
traditional press	1	10000	10000	15	666.7
toaster	1	8000	8000	15	533.3
toasting aid/hand gari	1	500	500	2	250.0
total			46300		7700

AMELIORATION OF THE LOCAL PRACTICE OF GARI PRODUCTION: CASE STUDY MUYUKA PRODUCTION ZONE

For grating, 99% of the producers donot possess a grating machine neither do they have a hand grater. What is been done is that, there are some people who do grating as their own business so they move around the town grating the cassava of all the producers. For this reason, grating here shall be considered only as a variable cost since machine belongs but to another person.

Table 11: Calculating cost of production

items	total price/production	annual price/Fcfa
sifting	1000	96000
pressing	1500	144000
washing	500	48000
peeling	1500	144000
grating charges	1000	96000
electricity	500	48000
frying	3000	288000
oil	1000	96000
wood	1000	96000
total	11000	1056000

Table 12: differential cost calculation

Differential cost		Value per year/Fcfa
Variable cost	Cost of raw material	1056000
	Cost of production	7700
Fixed cost	Depreciation cost	1466400
Total cost		2350100

But Gross profit = Income from sale – expenditure without tax

Expenditure= (Variable cost + Fixed cost) = 2350100 Fcfa

Calculating income or turn over capital

AMELIORATION OF THE LOCAL PRACTICE OF GARI PRODUCTION: CASE STUDY MUYUKA PRODUCTION ZONE

From the 235 kg of cassava approximately 77 kg of gari was obtained which is approximately 2 basins and the average annual price of gari in this area is 10000 FCFA. This gives a turn over capital per production of 20000 FCFA and hence the annual turnover capital is 200000×96 which is equal to **1920000**.

Hence gross profit= $1920000 - 2350100 = -430100$ FCFA

By applying the formula, breakeven point (BEP) = Fixed capital/variable charge margin, it means the producer needs a capital of about **3239947** Fcfa

II.7.3 PARTIAL CONCLUSION

This part of the work involved a survey on the process of gari production which was carried out in the Muyuka zone in the South West Region of Cameroon where we had to bring out items on the major actors in the sector, quality and quantity of raw material, major constraints, and finally evaluating the profitability of the sector.

From the results obtained, we can say that women are the major actors involved in this activity and is mainly done on house hold basis as a family business with the labour force constituting mainly family members. The primary material use fresh cassava, *Manihot esculenta*, Crantz and processing begins on the same day after harvesting this is a key determinant of the quality of gari. The most difficult unit operations as pointed out by producers are frying and peeling since they are very time consuming. A good number of producers thought the gari processing is profitable but from the calculations made, we can conclude that **the artisanal production of gari is not profitable since we had a negative balance balance of 430100 Fcfa and for this producer to have a breakeven point needs a capital of 3239947 Fcfa. And owing to the fact that they finance their production only with owned resources, it means it will be difficult for them to raise this capital and hence breakeven point may never be attained. This situation can be remedied by increasing the amount of cassava transformed per production which will entails changing from the artisanal scale of production to a semi industrial scale.** With respect to the products quality, gari is bought based on the color, the dryness, sourness or sweetness as preferred by the consumer. The main buyers of this products coming from urban towns like limbe, buea, Douala, and Nigeria. The demand of the Nigerians being perculiar in the sense that they want extremely sour gari.

AMELIORATION OF THE LOCAL PRACTICE OF GARI PRODUCTION: CASE STUDY MUYUKA PRODUCTION ZONE

Introduction

The traditional processing of gari from cassava roots involves several unit operations including peeling, washing, grating, dewatering, sieving, frying/toasting (garifying), re-sieving and packaging (Elijah *et al.*, 2013). According to Arlène *et al.*, (2009), three techniques are frequently used: traditional technology with grating done by hand; traditional technology with mechanised grating; and semi-mechanical technology (vibrating sieve, grinder, gas dryer, etc.). Whatever technology is used, certain stages in the production process are decisive in ensuring sanitary and organoleptic quality (Arlène *et al.*, 2009). Fermentation is crucial to eliminate toxicity (HCN) from the gari, and to meet organoleptic quality criteria (nuances in texture, taste and colour depending on the length of fermentation) (Arlène *et al.*, 2009). Proper cooking is important to reduce water content, foster good conservation and prevent mould. Additionally, its production surroundings, market preparation and transportation are also essential aspects of quality (Arlène *et al.*, 2009). It is generally produced in open-air sites where there are no sanitary installations or running water, and where effluents are not usually collected and peelings are not always removed, thus encouraging the proliferation of insects and animal pests.

Standards for gari exist in the Codex Alimentarius, and there are national standards for it in some African Countries like Ghana, Benin and Nigeria. Physicochemical criteria are found in all standards, but harmonization is required in regard to admissible limits. In practice, compliance with standards varies considerably from one type of gari to another and based on the criteria examined. For small artisans, quality is understood above all as the quality of the relationship with customers: a quality product is a product that has received no complaints or claims (Arlène *et al.*, 2009).

In this part of the work concerning the quality of the product, both physicochemical, functional properties and sensory analyses were performed to evaluate the quality standards of gari prepared during the survey.

0.6 MATERIALS AND METHODS

0.6.1 Materials

The materials used in this part of the work were gari samples and their respective cassava ground using a pelletizing machine having pore sizes of 200 mm.

AMELIORATION OF THE LOCAL PRACTICE OF GARI PRODUCTION: CASE STUDY MUYUKA PRODUCTION ZONE

0.6.2 Methods

Physicochemical, functional and sensory evaluations were carried out on gari samples, cassava samples were analysed for physicochemical and some functional properties.

0.6.3 Physicochemical Analyses

The physicochemical analyses carried out were: moisture content, ash content, pH, total acidity, starch, amylose and amylopectin.

0.6.4 Dry Matter/ Moisture Content

Dry matter of a sample is a total of all substances in the sample that do not volatilize under the desiccation conditions defined by the method used. The dry matter and moisture contents of both the cassava roots and gari were determined by the method put in place by the AACC (1999).

0.6.4.1 Principle

The method is based on the measure of the loss in matter after drying at 105°C for a time period of 24 hours.

0.6.4.2 Procedure

2.5g of gari and its corresponding cassava powder was weighed using electronic balance (Mark: Denver instrument, Model: APX-3202, max 3200, d=0.01g) and placed in a drying dish of known weight. The dish was then placed in a drying oven (mark: Heraeus, model: Kendro laboratory products, D-63450, Germany), pre-set at 105°C and left there for 24 hours sufficient time to attained constant weight. After removal from the oven, the dish was cooled in a desiccator, and then weighed again. The dry matter content represents the difference in mass before and after drying in the oven. The procedure was repeated 3 times.

0.6.4.3 Expression of results

The water content in 100g of fresh sample was calculated using the following formula:

$$WC \% = \frac{M_2 - M_0}{M_1 - M_0} \times 100 \quad (1)$$

Where: M_0 = mass (in g) of empty drying dish, M_1 = mass (in g) of sample before drying, M_2 = mass (in g) of drying dish + sample after drying.

The dry matter content (DM) was calculated using the following expression:

AMELIORATION OF THE LOCAL PRACTICE OF GARI PRODUCTION: CASE STUDY MUYUKA PRODUCTION ZONE

$$DM = 100 - \%WC \quad (2)$$

0.6.4.4 Ash Content

The ash contents of the gari and cassava samples were determined using the AOAC method (1990). Total ash is the residue of calcination of organic matter at 550°C.

- Principle

The principle consists of burning a sample previously dried in a muffle furnace until it attains a constant weight.

- Procedure

6g of the sample was placed into the ceramic ashing dishes that had been washed, dried, ignited and cooled in a desiccator, and weighed using an electronic balance (Mark: Denver instrument, Model: APX-3202, max 3200, d=0.01g). The dish containing the sample was then placed in the muffle furnace set at 550°C and incinerated until light gray ash was obtained. The ashing dish was then cooled in a desiccator and weighed when room temperature was attained. The procedure was repeated 3 times for each of the cassava sample.

- Expression of result

Total ash per 100 g of flour was calculated as:

$$\%Ash = \frac{\text{weight of residue}}{\text{weight of sample}} \times 100$$

Where weight of residue = (weight of crucible + residue) – weight of empty crucible.

0.6.4.5 pH and total titrable acidity (TTA)

The pH and total acidity was determined by the method of Brainbridge *et al*; (1988) with some modifications.

- principle

Total acidity is a measure of the acidity of a sample with respect to the process of fermentation that took place in course of its transformation.

- Procedure

4g of gari was weighed using a weighing balance and transferred into a beaker. 36 mL of distilled water was added to it. The prepared solution was then transferred into a centrifuge tube was agitated (Griffin flask) for 20 minutes at maximum frequency.

AMELIORATION OF THE LOCAL PRACTICE OF GARI PRODUCTION: CASE STUDY MUYUKA PRODUCTION ZONE

It was then centrifuged at 3000 rpm for 10 minutes. The supernatant was then collected. This supernatant was then used for the determination of pH using a pH meter at 25°C (characteristics of pH meter). For each sample, determination was been done in triplicate. 10 mL of the supernatant was then transferred into a 100 mL beaker, and 3 drops of phenolphthalein indicator was added and the mixture was titrated with a solution of 0.1M NaOH. The end point of titration was determined when the color changed from colorless to pink. The volume of NaOH added to obtain this change was recorded.

- **Expression of results**

The total acidity, determined as percentage lactic acid in 100g of sample was calculated as follows:

Percentage of total titrable acidity (% TTA) = volume of NaOH added (ml)*0.09*100/DM

Where 0.09 is a constant used in expressing acidity as percentage lactic acid and DM is the dry matter of the sample.

0.6.4.6 Total hydrogen cyanide content

The total hydrogen cyanide content was determined by the method put in place by Makkar *et al.*, (2007).

- **Principle**

This assay is based on the reaction of hydrocyanic acid of the sample with potassium hydroxide to form potassium cyanide (KCN). This potassium cyanide then reacts with sodium picrate, forming a red-colored compound. The color intensity which is proportional to the amount of hydrocyanic acid is then measured at a wavelength of 520 nm.

II-2-1-4-2 Procedure

2g of gari was measured and transferred into a burette and 62.5 ml of distilled water was added and allowed for 4 hours. This was then transferred into a round bottom flask and 1.25 ml of chloroform was added. It was then distilled and the distillate collected in a beaker containing 2.5 ml of 2% KOH. When approximately 10 ml of the distillate has been collected, the distillation stopped. This volume was then completed to 25 ml with distilled water. 5-mL aliquot of the well-mixed distillate is then introduced into a test tube and 5 ml of alkaline picrate solution is added.

AMELIORATION OF THE LOCAL PRACTICE OF GARI PRODUCTION: CASE STUDY MUYUKA PRODUCTION ZONE

The content of the test tubes is mixed and heated in a boiling water bath for 5 min for color development. The color intensity was then measured at 520 nm against the reagent blank (5 mL of distilled water and 5 mL of the alkaline picrate solution). using a spectrophotometer (Mark: JENWAY, model: 7310, serial n^o 39756, United Kingdom).

- **Preparation of standard curve**

241 mg of KCN was dissolved in a 1L volumetric flask with some distilled water and then completed to the mark, which gives 100 µg of hydrogen cyanide/mL. This solution was then diluted 20 times to have a concentration of 5µg of hydrogen cyanide/ml from which a standard curve was prepared in the range of 0.5 to 5µg equivalent of HCN as in the table below.

Table 13: Standard curve for cyanide quantification

Tubes/reagents	Blank	T1	T2	T3	T4	T5	T6	T7	T8	T9	T10
KCN(5µg/ml)	0.0	0.5	1.0	1.5	2.0	2.5	3.0	3.5	4.0	4.5	5.0
Distilled water (ml)	5.0	4.5	4.0	3.5	3.0	2.5	2.0	1.5	1.0	0.5	0.0
Alkaline picrate (ml)	5.0	5.0	5.0	5.0	5.0	5.0	5.0	5.0	5.0	5.0	5.0

- **Calculation**

From the straight line equation, $y=0.0505X$, $y=$ optical density (OD) and $X=$ Slope (Concentration of cyanide for that sample). This implies $OD/0.0505=X$

Thus the amount of cyanogens in samples in (mg/kg) = $(X*25/ (DM))*100$

Where $X= OD/0.0505$ and $DM=$ dry matter of sample and 25 is the dilution factor.

0.6.4.7 Total starch determination

The total starch content was determined by the method described by Dicko, (2006).

- **Principle**

Iodine (I_2) reacts with amylose and amylopectin to produce blue and brown colorations respectively. The absorption spectra of complexes of iodine-amylose and iodine-amylopectin are different.

AMELIORATION OF THE LOCAL PRACTICE OF GARI PRODUCTION: CASE STUDY MUYUKA PRODUCTION ZONE

Because of this, these complexes have different maximal absorption wavelengths. However it is considered that maximal absorbance at 580nm is due to both amylose and amylopectin. This can thus be used to measure the total starch in biological materials.

- **Procedure**

Preparation of standardization curve

0.5g of sample was dispersed in 20 ml of distilled water in a 100 mL conical flask and shaken. boiling distilled water was added until it reach the limit. The mixture was shaken and boiled for 5 minutes in a boiling water bath to obtain a turbid starch solution. At the end of this shaking, the mixture was cooled and completed to a volume of 100 ml with distilled water. This constituted a stock solution of starch at 5mg/ml. The standardization curve was established as follows by introducing the following reagents in to test tubes numbered from 1 to 10.

Table 14: Standard curve for starch determination

Reagent/Tube	Blank	1	2	3	4	5	6	7	8	9	10
(5mg/ml starch)/ml	0.00	0.01	0.02	0.03	0.04	0.05	0.06	0.07	0.08	0.09	0.10
Water (ml)	4.9	4.89	4.88	4.87	4.86	4.85	4.84	4.83	4.82	4.81	4.8
I ₂ /KI (ml)	0.1	0.1	0.1	0.1	0.1	0.1	0.1	0.1	0.1	0.1	0.1

The tubes were then incubated for 10 minutes at room temperature by keeping them away from light. Each tube was done in triplicate and the mean OD was calculated.

A curve of ([starch]) = f (mean OD), was plotted.

Preparation of the sample

0.1g of gari was weighed and 5ml of 1N KOH was then added. The mixture was then homogenized at room temperature using a vortex and neutralized with 5ml of 1N HCl. Neutrality was assured by using a pH meter. The mixture was then boiled in a water bath for 15 minutes, cooled and the volume adjusted to 10 ml with distilled water.

AMELIORATION OF THE LOCAL PRACTICE OF GARI PRODUCTION: CASE STUDY MUYUKA PRODUCTION ZONE

It was then centrifuged at 3500 rpm for 10 minutes and the supernatant collected. 0.05 ml of supernatant was collected in a tube test and 4.85 mL of distilled water was added and 0.1 mL of iodine solution. The tubes were then incubated at room temperature for 10 minutes and the optical densities (OD) read at 580 nm wavelength and the ODs recorded. The measurements were carried out in triplicate.

Table 15: Sample preparation for starch determination

Reagent/Sample	Blank	Sample
Sample (ml)	0	0.05
Distilled water(ml)	4.90	4.85
I ₂ /KI (ml)	0.1	0.1

- **Expression of results**

The equation obtained from standard is given as:

$$OD = m X + C$$

Which from the plot gave $Y = 4.08X$

Where X = concentration of starch in sample, m = gradient of standard curve (4.08) and C the y-intercept (0).

X was then deduced as follows:

$$X = \frac{OD - C}{m}$$

The percentage total starch was then calculated as follows

$$\% \text{ starch} = \frac{10X \times V_T \times 100}{10^3 \times V_p \times M_s \times dm} \times 100$$

Where V_T = total volume of extract (5ml), V_p = volume of specimen (0.05ml), M_s = mass of sample (0.1g), DM = dry matter content of sample.

AMELIORATION OF THE LOCAL PRACTICE OF GARI PRODUCTION: CASE STUDY MUYUKA PRODUCTION ZONE

0.6.4.8 Amylose and amylopectin determination

It was determined by the method of Dicko, (2006).

- **Principle**

It is based on the principle that iodine (I_2) reacts with amylose to produce blue-violet coloration. And it absorbs maximally at 720 nm.

- **Procedure**

Preparation of standard curve

0.5g of the amylose standard was weighed and introduced into a round bottom flask containing 100 ml of distilled water. Same quantity of amylose was used to determine the dry matter and water content of this sample. The round bottom flask was then introduced into a boiling water bath. After a sufficient time which allowing the dissolution for some amylose, the round bottom flask was removed and allowed to cool. The supernatant was then collected and introduced into a beaker. This served as the standard amylose solution of unknown concentration. In order to determine this concentration, the supernatant was collected the flask was then placed in an oven at 105°C for 24 hours, time to obtain a constant weigh. The mass of the ball and content was taken before placing it into the oven. The ball was then removed from the oven and the final mass was recorded. These data, combined with the data of dry matter content and water content of amylose have allowed to determine the concentration of amylose stock solution.

it should be noted samples optical densities were at the same time as for starch but the wavelength was change to 720nm.

- **Expression of results**

The standard plot gave a straight line equation as follows:

$Y = 14,442X$, $Y =$ Optical density of samples (DO), $X =$ Amylose concentration, from this equation, X was calculated as follows

$$X = DO/14,442$$

The amylose concentration also was calculated using the same formula as for in starch.

AMELIORATION OF THE LOCAL PRACTICE OF GARI PRODUCTION: CASE STUDY MUYUKA PRODUCTION ZONE

From the results obtained for total starch and amylose, using the assumption that starch is made up of amylose and amylopectin, the concentration of amylose was determined by difference.

0.6.5 Techno functional Properties

The functional properties determine the application and use of food material for various food products. The functional properties determined were: degree of pregelatinisation, water absorption capacity and pasting properties of gari.

0.6.5.1 Water absorption capacity (WAC)

The water absorption capacity water at room temperature was determined by using the method described by Philip *et al.*, (1988) with some modifications.

- **Procedure**

2 g of samples (M0) (with dry matter = DM) was mixed with 25 ml of distilled water, shaken for 5 minutes and allowed to stand for 15 minutes. The set up was then centrifuged at 6500 rpm for 10 minutes at room temperature using a centrifuge of (Mark: Heraeus-Kendro Lab products, model: Biofuge primo R, type: D-37520, Fab n°: 284678, Germany. The wet sediment was weighed (M1) before being dried at 105°C for 24 hours and also weighed (M2). The procedure has been repeated 3 times for each of the sample.

- **Expression of result**

The water absorption capacity (WAC) as well as the solubility index (SI) was calculated as follows at room temperature (g water/g flour

$$WAC_r = \frac{M1 - M0}{DM}$$

Where r is real, M1 is mass of wet sediment, M0 is mass of sample.

0.6.5.2 Degree of pregelatinisation

This was determined using the method described by Cabrera *et al.*, (1984) with some modifications. Since gari is a pre gelatinized product by cooking which occur during the frying operation, we wanted to see the degree that this was done during the local frying.

AMELIORATION OF THE LOCAL PRACTICE OF GARI PRODUCTION: CASE STUDY MUYUKA PRODUCTION ZONE

- **Procedure**

0.1g of ground cassava powder was weighed and put into a centrifugal tube and 10mL of distilled water was added to it and then agitated using the Griffin flask at maximum frequency and then introduced in a boiling water bath for about 2 hours. This time is estimated to be enough to gelatinize all the starch present in the respective raw materials of our various gari sample. This gave a 100 % degree of gelatinization. The tube and its content were then centrifuged at 3000 rpm for 10minutes. 1ml of the supernatant was then pipetted in to a clen testube and 2mL of lugol solution diluted 25 times added. The optical absorbances were then read at a wavelength of 620nm and results recorded. For each sample test was done in triplicates. A 0 % degree of gelatinisation was also prepared with the only difference here being that no boiling is involved.

The gari samples were treated in the same way as for determining the 100 % degree of gelatinization but no boiling was involved.

- **Expression of results**

The degree of pre gelatinization was calculated as follows:

$$\% \text{ DG} = (D.O - D.O_0 / D.O_{100} - D.O_0) * 10000 / DM$$

Where D.O is the optical density of the gari samples

D.O 100 is the optical density of the corresponding cassava at 100 % DG

D.O 0 is the optical densities of the corresponding cassava at 0% DG

0.6.6 Pasting properties

This is done in order to study the pasting profile of starch in our various samples.

- **Procedure**

The pasting properties were determined following the method of Omodamiro *et al.*, (2007) using approximately 3 g of gari samples on dry matter bases in 25 ml distilled water using a RVA (Perten instruments, Australia) with the following settings: initial temperature of 50°C which was held for 1 minute in order to study the cold water viscosity and then heating at the

AMELIORATION OF THE LOCAL PRACTICE OF GARI PRODUCTION: CASE STUDY MUYUKA PRODUCTION ZONE

rate of 12.16°C/min to a temperature of 95°C. The temperature was then held for 2 minutes 30 seconds and then cooled to 50°C at the rate of 12.16°C/min and held for 2 minutes. The total time for this analysis was 13 mins and the speed of the motor was 160 rpm. A summary of the treatment parameters is given in Table below. Pasting parameters were measured over time. The pasting parameters included Final viscosity (FV), Setback (SB) and Breakdown (BD), Peak viscosity (PV) and pasting temperature. Results of all these parameters were read directly from the RVA.

0.6.7 SENSORY ANALYSES

- **Selection of panelists**

Different gari samples produced with variation in varieties and fermentation periods were scored by a semi-trained sensory panel using a modified version of quantitative descriptive analysis (QDA) of Tomlins *et al.*, (2012) since standards were not provided.

18 Panelists all students were randomly selected from the campus of ENSAI, University of Ngaoundere based on them first of all accepting that they know gari very well and that they are also regular consumers of gari. Sessions were conducted in a sensory evaluation room at ambient temperature (about 22-25 °C).

- **Initiation of judges and generation of sensory attributes**

All of the judges were presented with non-coded samples of gari in order to familiarize themselves to the product and to generate the terms of the sensory evaluation. Sensory attributes were generated guided by the panel leader. The parameters generated were according to the five human senses as shown in **annex 4**.

The next session known as pre-test was then carried out to test the reproducibility aptitude of the judges. This part of the analyses was done by using four samples among the twelve total with each sample coded with three figures random numbers generated randomly using Microsoft excel. Samples were served on white plastic cups in random order to each panelist, who had to score sensory attributes on a 11.05 cm unstructured scale, anchored with terms related to minimum intensity at the left end and maximum intensity at the right end of the different attributes (**annex 5**). Each panelist was given a glass of water to rinse the mouth between samples in order to completely remove the taste of the former.

- **Main sensory evaluation**

In this part, panelists tasted all 12 samples in order to effectively bring out the specific attribute of each sample with respect to the attributes previously generated. This was done in three sessions each session having three trials in which 4 samples were presented to panelists coded a three digits codes. Each panelist then described the intensity of the perceived attribute according to the scale generated during the generation test.

0.7 Statistical analyses

All data (physicochemical, functional and sensory analyses) were treated using XLSTAT Version 2007.8.04 package. The main analyses undergone in this respect were analysis of variance (ANOVA), Principal Component Analysis (PCA), Hierarchical clustering and correlations.

AMELIORATION OF THE LOCAL PRACTICE OF GARI PRODUCTION: CASE STUDY MUYUKA PRODUCTION ZONE

0.8 RESULTS AND DISCUSSION

0.8.1 Physicochemical and functional characterization of gari samples

The results are given with respect to the influence of variety, fermentation period and pressing mode as follows:

Table 16: ANOVA table for the variation of physicochemical and functional parameters as a function of pressing method

Pressing method	HCN (mg/kg)	Acidity (%)	Ash (%)	Starch (%)	WAC (%)	Final viscosity (mPas)	Pasting temp. (°C)	breakdown viscosity (mPas)	Peak viscosity
I	34.912 ^a	0.196 ^a	1.052 ^a	48.3 ^a	355.361 ^a	2505.17 ^a	66.42 ^a	297.6 ^a	1852.5 ^a
T	34.934 ^a	0.212 ^a	1.080 ^a	48.903 ^a	366.873 ^a	2459.9 ^a	69.615 ^a	143.06 ^a	1703.67 ^a

Table 17: ANOVA table showing variation of physicochemical and functional properties with fermentation time

Fermentation time	HCN (mg/kg)	Acidity (%)	Ash (%)	Starch (%)	WAC (%)	Final viscosity (mPas)	Pasting temp. (°CD M)	breakdown viscosity (mPas)	Peak viscosity (mpas)
0	59.971 ^a	0.121 ^d	1.007 ^b	59.666 ^a	381.5 ^a	2361.3 ^{a,b}	64.8 ^a	2361 ^{a,b}	1862 ^a
1	37.3 ^b	0.229 ^b	0.976 ^b	47.289 ^b	323.5 ^b	2530.2 ^{a,b}	73.6 ^b	2530 ^{a,b}	1840 ^a
2	24.102 ^c	0.257 ^a	1.160 ^a	47.717 ^b	368.8 ^a	2224.3 ^b	61.07 ^a	2224 ^b	1479 ^b
3	18.318 ^d	0.208 ^c	1.12 ^{a,b}	39.732 ^c	370.6 ^a	2814.4 ^a	72.59 ^b	2814 ^a	1932 ^a

AMELIORATION OF THE LOCAL PRACTICE OF GARI PRODUCTION: CASE STUDY MUYUKA PRODUCTION ZONE

Table 18: ANOVA table of physicochemical parameters of gari with respect varieties of cassava

Varieties	HCN (mg/kg DM)	Acidity (% DM)	Ash (% DM)	Starch (%DM)	WAC (%DM)	Final viscosity	Pasting temp. (°C DM)	breakdown viscosity (mPas DM)	Peak viscosity (mPas DM)
8017	30.42 ^b	0.179 ^c	1.019 ^a	49.435 ^b	300.958 ^c	2546.88 ^a	68.22 ^a	431.6a	2041.36 ^a
Owe stick	34.2 ^b	0.204 ^b	1.097 ^a	55.357 ^a	359.059 ^b	2507.03 ^a	65.534 ^a	42.84 ^c	1590.5 ^b
Kumba stick	40.145 ^a	0.229 ^a	1.082 ^a	41.011 ^c	423.3 ^a	2393.75 ^a	70.229 ^a	186.5 ^b	1702.38 ^{bi}

Analysis of variance (ANOVA) at (P<0.05) of the results obtained from physicochemical analyses shows that the pressing method did not have a significant effect on the physicochemical and functional properties of the gari samples but was significant for varieties and fermentation time.

The implication of cyanogenic glucosides in cassava and cassava products has really influenced its utilization rate in human alimentation. But in Sub Saharan African Countries it still constitutes a major part of our food regimes. From the analysis carried out on gari samples, the cyanide content varied significantly from 59.971^a 37.3^b 24.102^c 18.318^d for unfermentation, one day fermented, two days fermented and three days fermented gari samples respectively. According to the CD-ARS 854:2012(E) standards for gari, the cyanide content determined as total cyanide should not exceed 20 mg/kg. From the values obtained, it shows that only gari fermented for three days is within limit and the others are above the recommended values. Similar range of values were obtained by Owuamanam *et al.*, (2010) particularly on the third day of fermentation where he had approximately 18mg/kg of HCN. The other values may not have coincided due to differences in cassava varieties. According to FIIRO, (2005) the most effective traditional method of reducing cyanide in gari is by fermentation over a period of 5 to 6 days. The higher levels of cyanide in the zero, one and two days fermented gari can be due the high pH of the medium which influence the breakdown of the cyanogenic glucosides to cyanohydrins and hydrogen cyanide.

AMELIORATION OF THE LOCAL PRACTICE OF GARI PRODUCTION: CASE STUDY MUYUKA PRODUCTION ZONE

Since at these time intervals, enough hydrolysis have not yet taken place to convert the sugars into lactic acid which eventually will reduce the pH of the medium which renders the glucosides more stable. With respect to the varieties of cassava, the cyanide content was significantly different for all three varieties. This can be due to differences in cyanide content in each variety and the the age of the cassava at harvest.

Ash content of food product is an indication of the mineral content of the food products; values close to 0.5% ash contents is a good representation of minerals content (Adeleke and Odedeji, 2010). From the analysis carried out on ash content of the gari samples, it ranges from 1.007b 0.976b 1.160a and 1.12a,b for no fermentation, one day fermentation, two days fermentation and three days fermentation respectively. There results obtained showed that the ash content of the non -fermented and one day fermented gari were not significantly different at $p < 0.05$ and that between two days and three days fermentation also were not significantly different either. The result obtained for the non and one day fermented gari were also not significantly different. All values obtained fell within the acceptable limit of ash content in gari according to either the *codex alimentarius* which states that the ash content should not exceed 2.75% and the CD-ARS 854:2012(E) standards which states that it should not exceed 1.5% for good quality gari. According to Oduro *et al.*, (2000), values below 1.5% are a poor reflection of ash (minerals) in gari. With respect to varieties the ash contents of the gari samples were not significantly different at $p < 0.05$.

Analysis of variance with respect to fermentation time indicated that the acidity had a significant difference at $p < 0.05$. The values moved from 0.121^d, 0.229^b, 0.257^a and 0.208^c for the unfermented, one day fermented, two days fermented and three days fermented gari respectively. The trend shows that there was a constant increase from the unfermented to the two days fermented gari and then a decrease at the third day of fermentation. This drop in total acidity can be attributed to the different varieties of cassava used, experimental conditions and also the uncontrolled fermentation carried out during sample preparation. These increases in titratable acidity could be attributed to the activity of the lactic acid bacteria during the fermentation process, which leads to the production of organic acids and other metabolites causing souring or acidification of the product. Souring of cassava dough during fermentation is an important and desirable quality attribute in gari production.

AMELIORATION OF THE LOCAL PRACTICE OF GARI PRODUCTION: CASE STUDY MUYUKA PRODUCTION ZONE

Acid production has been reported to be responsible for product stability, flavour development, and cyanide elimination during cassava fermentation (Okigbo, 1980). Sefa-Dedeh *et al.* (2004) have reported that lactic acid fermentation exhibits antimicrobial effects on pathogenic microorganisms due to the presence of acid. With respect to varieties, the titratable acidity was significantly different this can be attributed to uncontrolled fermentation and differences in the carbohydrate contents of the different varieties.

The starch content of the gari samples was observed to decrease with increase in fermentation time as shown on the table. The decrease was significant at $p < 0.05$ for the unfermented, one and two days fermented and three days fermented gari but between day one and two the difference was not significant. These decreases in the starch content with increased fermentation time are due to the breakdown of starch molecules into sugars by microorganisms during the fermentation process. Earlier research revealed that during the first stage of the spontaneous fermentation process, the starch in the cassava is hydrolysed by corynebacterium to give sugars (Diop, 1998). These sugars are then metabolised by microorganisms to organic acids, which hydrolyse the cyanogenic glucosides in the cassava and releases HCN. With respect to the varieties, the starch contents of the gari were significantly different. This can be attributed to different age at harvest.

Water absorption capacity is the ability of a flour to absorb water and swell for improved consistency in food. It is desirable in food systems to improve yield, consistency and give body to the food. The percentage water absorption capacity of all gari samples were very high as shown on the table above. It ranges from 323.5% to 381%. This correlates with the report of Chen and Lin (2002) who said that the water absorption capacity of any food product, either flour or grain, is the ability of such product to entrap a large amount of water. Results obtained as a function of the fermentation time were not significantly different for unfermented, two and days fermented gari at $p < 0.05$. But the one day fermented gari was significantly different from the others this can be attributed to experimental conditions. But generally we can conclude that fermentation did not influence the water absorption capacity of the gari samples. Similar observation was made by Udoro *et al.*, (2014). These high values of water absorption capacity indicates that all gari are very suitable for drinking (soaked gari) which is a common method of its consumption.

AMELIORATION OF THE LOCAL PRACTICE OF GARI PRODUCTION: CASE STUDY MUYUKA PRODUCTION ZONE

Arawande and Komolafe reported a water absorption capacity which ranges between 215 – 445% this therefore means the values obtained from this study is within range of accepted values of good quality gari. With respect to the varieties, the WAC was significantly different. This can be attributed to the difference in starch destruction during frying.

The results of the major pasting properties determined are given in the table above and they are the: the pasting temperature, final viscosity, breakdown viscosity and the final viscosity.

The pasting temperature which provides an indication of the minimum temperature required to reconstitute (in hot water) a given sample and also indicate energy costs ranged from 61.07 to 73.6. From analysis of variance, it shows that there is no significant difference between the unfermented and two days fermented gari on the one hand and on the other hand there was no significant difference between the one day and three days fermented gari samples at $p < 0.05$. Pasting temperature is characterized by an initial change in the viscosity due to the swelling properties of the starch granules. Pasting temperature, which is a reflection of the swelling of the starch granules, is affected by the starch concentration. The gelatinization temperatures are usually characteristic of a particular starch and usually lie between 55-70°C. Udoro *et al* 2014 found out that variables like varying fermentation time had no effect on the pasting temperature. This difference may be as a result of differences in experimental conditions since the difference was not for all samples some were not significantly different at $p < 0.05$. With respect to varieties, the pasting temperatures were not significantly different.

For the peak viscosity, the three days fermented gari had the highest value while the two days fermented one had the least. The values of the unfermented, one day fermented and three days fermented gari were not significantly different at $p < 0.05$ but were at $p < 0.05$ significantly different from the two days fermented gari. Peak viscosity indicates the water binding capacity of starch grains and the ability of the starch to swell freely before their physical breakdown. It is an indication of the extent of starch damage or ease of cooking of the starch fraction in the gari (Balagoplan *et al.*, 1988). Thus the three day fermented gari could be said to have the best water binding capacity and its starch may be one of the easiest samples to cook (gelatinize). With respect to the varieties, the peak viscosities were not significantly different for Kumba stick and Owe stick but 8017 was significantly different. This can be attributed to differences in grain or granule sizes between the different varieties.

AMELIORATION OF THE LOCAL PRACTICE OF GARI PRODUCTION: CASE STUDY MUYUKA PRODUCTION ZONE

The breakdown viscosity of the gari samples were not too variable. The unfermented, one day and two days fermented gari samples were not significantly different at $p < 0.05$ meanwhile the unfermented, one day and three days fermented gari were either different at $p < 0.05$. But the three days fermented gari had the highest value. Breakdown viscosity reflects the ability of the sample to withstand shear stress and heating during cooking. Thus samples with lower values may not with stand cooking. With respect to the varieties the breakdown viscosities were significantly different which implies that they had different potentials to with stand cooking. The highest value was obtained for 8017 which implies it can with stand cooking more than the rest.

The final viscosity values ranged from 2224.3mPas to 2814mPas with the unfermented, one and three days fermented gari samples presenting no significant difference at $p < 0.05$ and the unfermented, one and two days fermented gari samples showing no significant difference at $p < 0.05$. Final viscosity indicates the change in viscosity after the sample was held at 50°C . It shows the ability of the starch to form stable and viscous paste after cooking (Maziya Dixon *et al.*, 2007). Gari is prepared for eating by stirring some quantity of gari granules in hot water to form a thick paste or dough ('eba' as called in Nigeria). The dough is moulded with the palm, deeped in soup or stew and swallowed (Achinewhu and Owuamanam, 2001). The mouldability of the dough influences the consumer acceptability of the gari, which is directly related to the final viscosity of the paste. Gari can also be taken as a snack by soaking in water and drinking it with roasted ground nut or dried fish. The three days fermented gari which had the highest value for peak viscosity (2814.4mPas) could be said to be best suited for drinking. The results obtained in the study therefore indicate that different fermentation conditions are required for producing gari that could be used for different purposes, may be for eating with soup or stew, or for drinking. With respect to varieties, the final viscosities were not significantly different at $P < 0.05$.

0.9 Sensory Analysis

This was done in two parts: the pre-test and the main test

AMELIORATION OF THE LOCAL PRACTICE OF GARI PRODUCTION: CASE STUDY MUYUKA PRODUCTION ZONE

0.9.1 Pre –test

Among the 18 panelists used, after analyzing their response on XLSTAT, all of them were retained for the main test. This was based on the results obtained from the analysis of variance in which we found out that all panelists were homogenous in defining three of the attributes (all of them fell on one class with respect to these attributes). And from Agglomerative Hierarchical Clustering (AHC), using three classes we saw that most of the panelists had zones where the response were very homogenous.

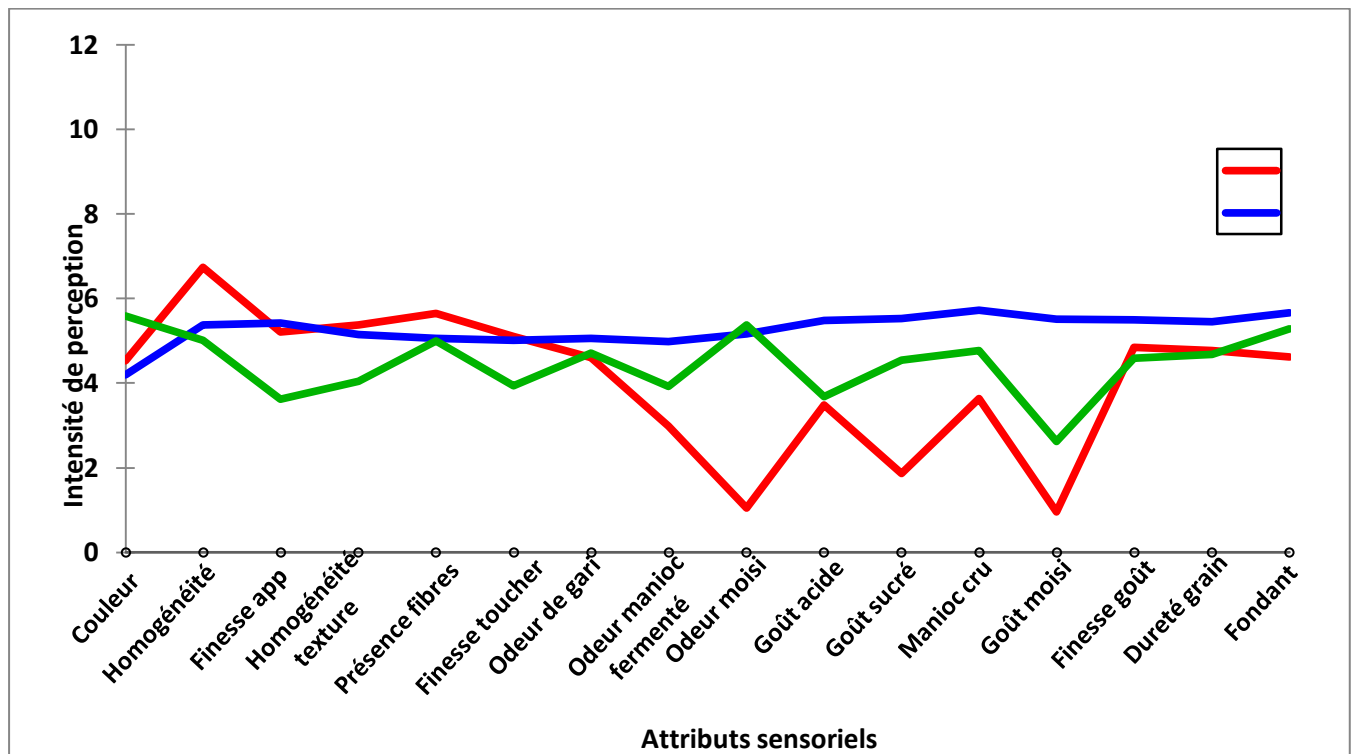

Figure classes group comparison

From this graph we can see that the panelists are homogenous from colour to about finess to the touch and from taste finess to meltability (fondant). For these reasons all the panelists were maintained for the main test.

0.9.2 Main test

In this part we are more concerned with the sensory attributes of the gari samples as perceived by the judges. The principal analytical tool used here is the Principal Component Analysis (PCA) which is simply a representation which summarizes the relationships between sensory attributes.

AMELIORATION OF THE LOCAL PRACTICE OF GARI PRODUCTION: CASE STUDY MUYUKA PRODUCTION ZONE

The results from the PCA of the attributes showed that, up to 71.61% of these relationships can be represented by the first two main components (F1 and F2) as shown on Figure xx. From the graph it can be seen that the

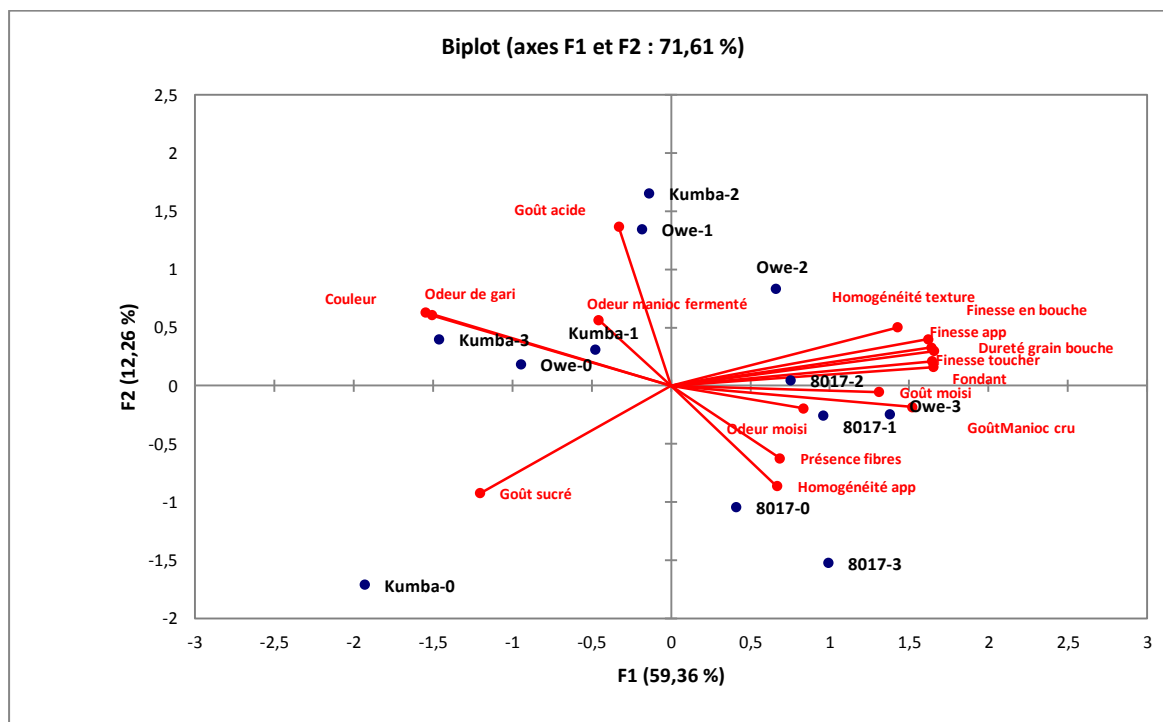

Figure Sensory attributes of gari as affected by cassava variety and fermentation time.

(Variety: Kumba, Owe and 8017/ fermentation time: 0,1,2,3 (attached to the names of the varieties)).

From the figure it can be deduced that attributes like homogeneity in appearance (color), presence of fibres, odour of mold, raw cassava taste are positively deployed on the F1 axis. Attributes like colour, sourness, gari flavour, fermented cassava odour are deployed on the negative F2 axis. Attributes like, homogeneity in texture, finess in the mouth, finess in color, hardness of grains in the mouth, finess to the touch, meltability in the mouth are positively deployed on the F2 axis and attributes like sweet taste is on the negative F1 axis. From the graph, gari samples can be differentiated both by variety and fermentation time. The graph shows that Kumba-0 is mainly characterized by a sweet taste. It also reveals that 8017-1, 8017-2, 8017-3 and Owe-3 are mainly characterized by homogeneity in their color, the presence of fibres, smell of mold, mold taste, raw cassava taste.

AMELIORATION OF THE LOCAL PRACTICE OF GARI PRODUCTION: CASE STUDY MUYUKA PRODUCTION ZONE

In addition, samples like 8017-2 and Owe-2 are characterized by homogeneity in texture, finess in the mouth, finess in color, hardness of grains in the mouth, finess to the touch, meltability. Finally, it reveals that Kumba-3, Owe-0, Kumba-1, Owe-1, Kumba-2.

To really confirm if these attributes are specific for each variety of cassava, we shall do a sensory profile for each variety as shown below.

From the sensory profile of kumba stick, it shows that its sweetness is the characteristic attribute for Kumba-0. Kumba -2 is characterized by its acidic state and finess. This goes same for the other varieties as we can distinguish the attributes with the highest points on the axes of the various profiles.

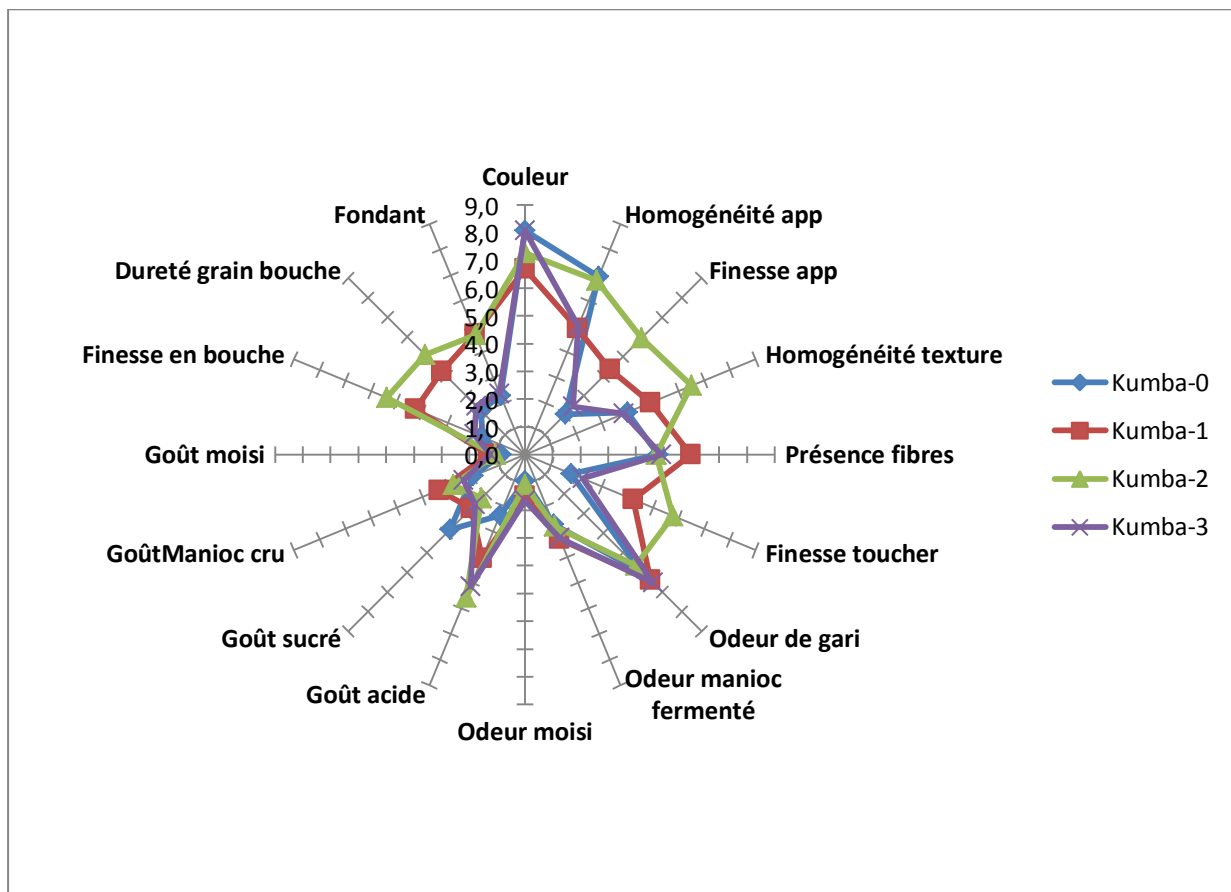

Figure sensory profile Kumba

AMELIORATION OF THE LOCAL PRACTICE OF GARI PRODUCTION: CASE STUDY MUYUKA PRODUCTION ZONE

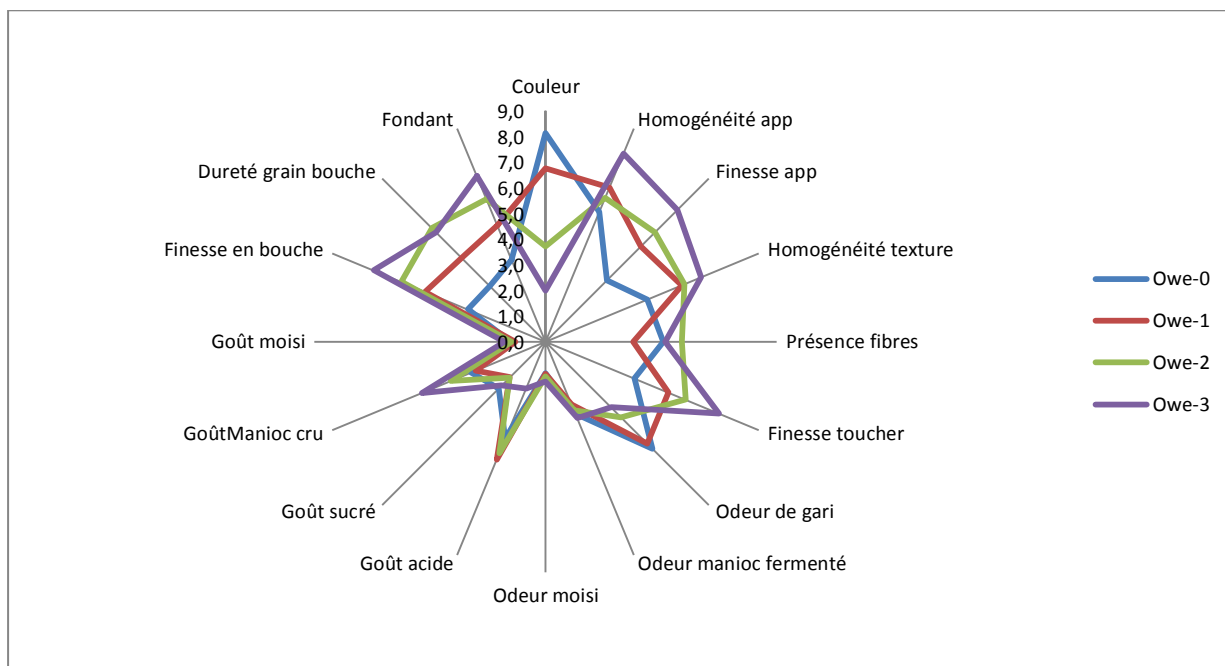

Figure sensory profile Owe

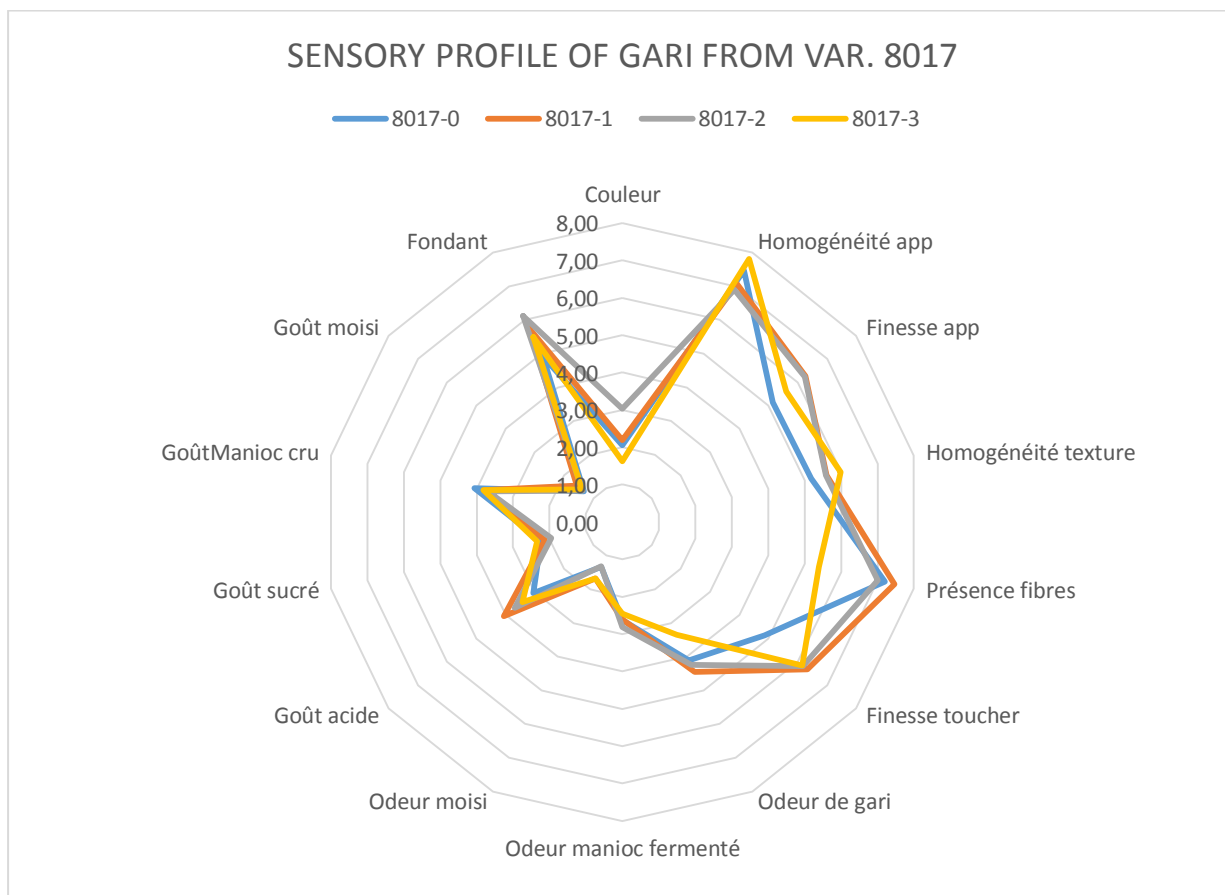

Figure sensory profile of 8017

AMELIORATION OF THE LOCAL PRACTICE OF GARI PRODUCTION: CASE STUDY MUYUKA PRODUCTION ZONE

From the biplot above, the 12 samples used for this analysis have been partitioned across the F1 and F2 axes into four classes. This partitioning is equal to the number of classes obtained from agglomerative hierarchical clustering (AHC) but the only difference is that the disposition of the samples in the various classes are not maintained. The results for AHC is given in the table below.

Table 19: Classes of gari samples with respect to their sensory attributes

Classes	1	2	3	4
	8017-0	8017-3	Kumba-0	Kumba-1
	8017-1		Kumba-3	Kumba-2
	8017-2		Owe-0	Owe-1
	Owe-2			
	Owe-3			

The difference in partitioning of the samples in the two representation can be attributed to the fact that in ACP, portioning is done with respect to affinity following the number of axes generated. In this case, 11 axes were generated but the most representative were the F1 and F2. Meanwhile AHC does a classification base on affinity to the attributes generated.

Pearson Correlation between all sensory attributes shows that the color is negatively correlated $P < 0.05$ ($r = -0.591$) to the presence of fibres. This can be explained by the fact the presence of fibre in gari is not desirable and can alter the final color of the gari since during the frying phase when the cream white color of gari is produce the fibres will interfere since they donot constituted of starch molecules.

Moreso, we obtain that the finess in the appearance of the gari is positively correlated to homogeneity in texture and finess to the touch $P < 0.05$ with $r = 0.937$ and 0.99 respectively. This is due to the fact that finess in appearance of the gari will translate to homogeneity in texture and eventually to finess when touched since the sizes of the grains will not be too different.

AMELIORATION OF THE LOCAL PRACTICE OF GARI PRODUCTION: CASE STUDY MUYUKA PRODUCTION ZONE

We also obtain from this matrix that homogeneity in the texture of the gari is positively correlated to finess to the touch and its melting ability. This can be due to the fact that when the texture of the gari is homogenous, the grain sizes fine when touched, the melting ability too will be high since smaller grains absorb water easily and solubilize easily. Same reason accounts for the fact that finess to the touch is positively correlated to melting ability $r=0.965$ at $p<0.05$.

In addition, we obtained that the odor characteristic to gari is negatively correlated to raw cassava and mold tastes. This can be explained by the fact that gari odor develops during the fermentation process were carbohydrates are broken down to aldehydes and these compounds are responsible for the characteristic flavour of gari. The gari odor is also enhanced during the frying operation. If these processes are effective, then the taste of raw cassava and mold will not be sensed.

All other parameters that have not been mentioned here implies the correlation was not significant or it was significant but no biochemical or process related reason can account for the relation.

Comparing results of sensory and physicochemical and functional properties of the gari samples, and looking at acidity which is a common parameter in both cases, sensory analysis results shows that acidity is characteristic for Kumba-3, Kumba-1 and Owe-0 and that sweetness is characteristic only for Kumba-0. Meanwhile results from physicochemical analysis shows that acidity is characteristic for Kumba-3, Kumba-1, Kumba-2 and Owe-2 and on the opposite quadrant that signifies sweetness, we have Owe-0, Kumba-0 and 8017-0. This implies there are always variations in sensory and physicochemical analysis.

PARTIAL CONCLUSION

In this section on the product quality, we investigated the effect of pressing method, fermentation time and varieties on some physicochemical and functional properties of gari and a sensory evaluation was also performed on the gari. Results showed that the pressing method had no effect on the physicochemical and sensory properties of the gari at $p < 0.05$. Meanwhile on the other hand, effects of fermentation time and varieties were significantly different at $P < 0.05$. Sensory analysis results showed that gari samples can be grouped based on fermentation time and varieties. From principal component analysis, samples were grouped into four different classes based on the affinity to the different axes with the first two being the most representative. By agglomerative hierarchical clustering, gari were also classified into four classes based on the different sensory attributes generated.

Comparing results for physicochemical and sensory analysis showed a little variation in the representation of the gari samples with respect to acidity which is a key parameter in both cases.

AMELIORATION OF THE LOCAL PRACTICE OF GARI PRODUCTION: CASE STUDY MUYUKA PRODUCTION ZONE

PROPOSED AMELIORATIONS

Due to the numerous impact faced by processors with respect to the ingestion of cyanide from improperly fermented gari in terms of frying difficulties posed by the local village fryer; there is need to optimize the traditional gari processing methods with the view of reducing fermentation time and achieving the elimination of cyanide while maintaining gari quality. In this respect we shall have the following propositions:

- Seedling freshly grated mash with already fermented one.
- The use of a fryer of large capacity and with a chimney to evacuate smoke

The chimney will serve for effective gas evacuation, the elevated position of the fryer will help improve the sitting posture and the increase capacity will aid in reducing the total frying time.

Improved village frying models

Some gari fryers known as improved fryers have been in used which include:

- The university of Ibadan improved fryer
- IITA model
- The RAIDS (Rural Agro-Industrial Development Scheme) model
- Mechanical models

In view of this project we shall propose two models: the IITA model involving in a single person and the University of Ibadan model which needs two persons.

The IITA model

It is a one-man operated gari fryer with an elevated fireplace oven. The frying pan is circular, made of cast iron and is smaller than the normal traditional pan in diameter but has more depth. The pan sits on a circular oven which has a chimney and can use either dense rice husk or wood shavings as fuel.

Advantages of model

It eliminates smoke and heat hazards from the operator. As a result of the elevated fireplace, the sitting position and comfort of the operator are enhanced. The capacity of the fryer is much higher than the usual traditional fryer.

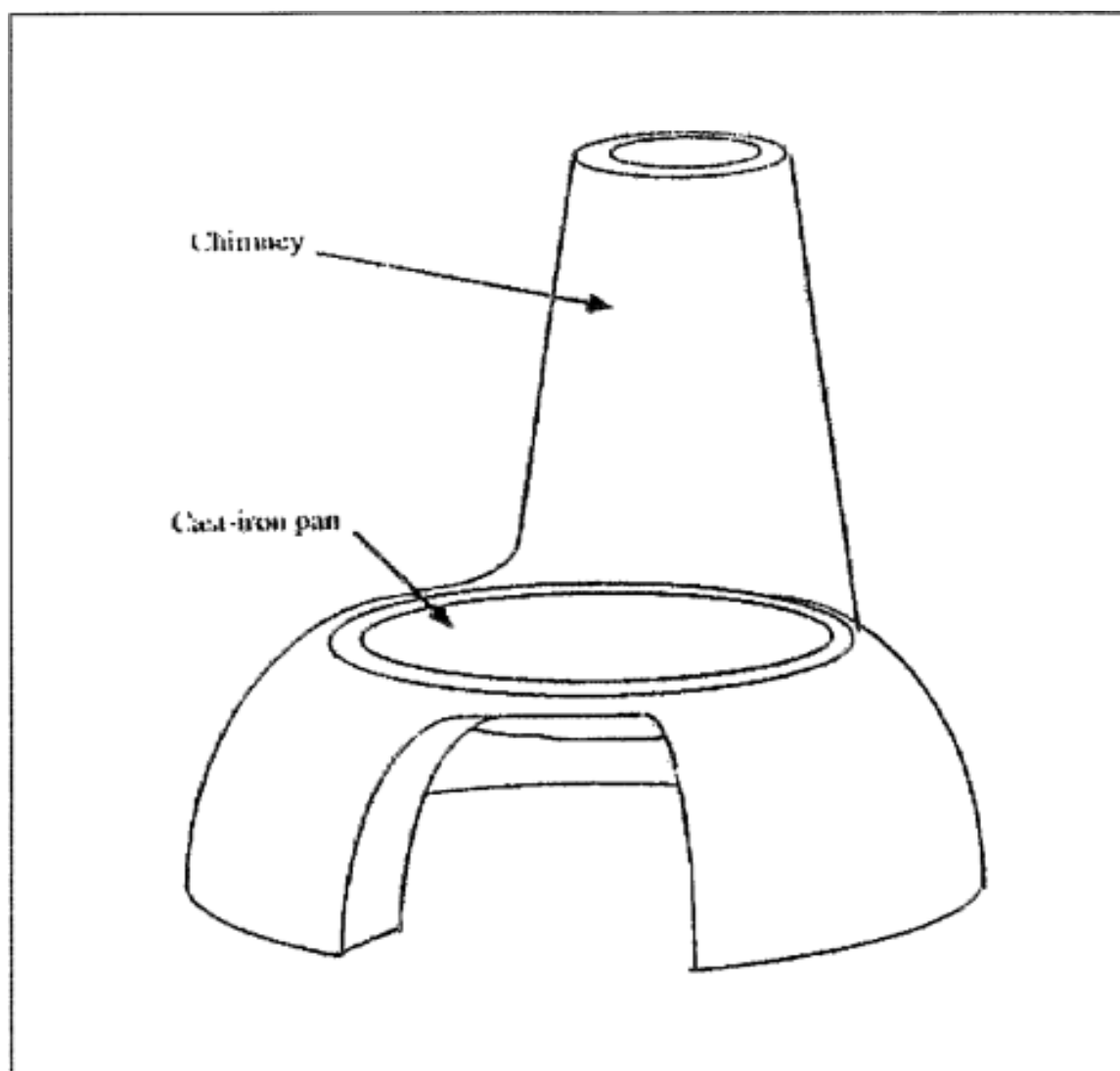

Figure 18: The University of Ibadan model

It is made up of a fire place oven with a chimney and a frying pan. The frying pan which is 200cm x 60un x 10cm is designed to have a trapezoidal shape with its sides inclined at 60° to the horizontal.

AMELIORATION OF THE LOCAL PRACTICE OF GARI PRODUCTION: CASE STUDY MUYUKA PRODUCTION ZONE

The inclination of the sides allows for gradual gravitational flow of gari down the sides of the fryer. It is made from a 4mm thick black steel sheet, which is not easily corroded and does not turn black after heating. The frying pan has an opening or chute on one side for discharging the finished product into a receiving pan. The frying pan sits on a rectangular fireplace built of Clay which is 60cm high and has an opening on one side of the breadth or width from where fire wood is fed into the oven, while the other width carries the chimney. There are two small ventilation openings on one side of the length. The Wall thickness of the fireplace is 22.5cm and the effective volume of the heating chamber of the fireplace is 0.72m³. It can use up to 20kg of wood as source of heat. The fryer is operated by two people sitting on both ends of the fireplace without ventilation heat. Field tests amongst gari producers showed that the improved models had the following advantages over the village fryer:

- The nuisance of smoke was totally eliminated
- Sweating by the operator was drastically reduced as a result of the improved fireplace
- The capacity and rate of frying were increased.

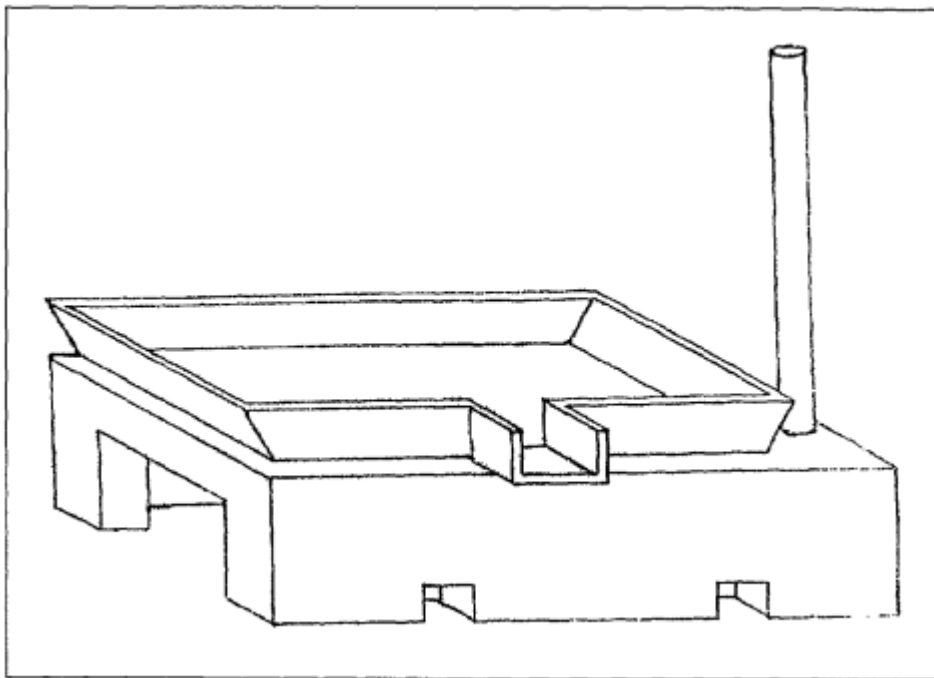

Figure 19: Ibadan improved traditional fryer

AMELIORATION OF THE LOCAL PRACTICE OF GARI PRODUCTION: CASE STUDY MUYUKA PRODUCTION ZONE

Introduction

The objective of financial analysis is to ascertain whether the proposed project will be financially viable in the sense of being able to meet the burden of servicing debt and whether the proposed project will satisfy the return expectations of those who provide the capital. Such analysis gives us information as to what concern:

Investment outlay and cost of project, Means of financing , Projected profitability, Break-even point (payback period), Cash flows of the project

In the zone of study, gari production is done at house hold level. But nevertheless there is group known as the root and tubers made of about 200 members all involved in cassava transformation in its diverse products but gari is the major product. Under the terms of PIDMA which involves 10, 40, and 50 %, its means the root and tuber, members of Muyuka will group the self in order to realize this investment project.

FINANCIAL ANALYSES

In order for this project to be put in place, the following initial investments are going to be required:

Table 20: initial cost of investment

cost of invetment			
item	quantity	cost	annual cost
grating machine	1	2500000	2500000
jack press	1	1200000	1200000
fryer	2	16000000	32000000
fermenting rack	10	50000	500000
building	1	2000000	2000000
mechanical sifter	1	1500000	1500000
balance	2	100000	200000
sealing machines	4	500000	2000000
setting up of equipments	1	500000	500000
formation	1	250000	250000
toyota hilux	1	8000000	8000000
milling machine	1	3000000	3000000
diverse equipments	1	1000000	1000000
working capital	1	135628800	135628800
total			190278800

AMELIORATION OF THE LOCAL PRACTICE OF GARI PRODUCTION: CASE STUDY MUYUKA PRODUCTION ZONE

After estimating the investment cost, we are then going to determine the depreciation cost of the different equipments by taking in to consideration their shelf lives. It is calculated as follows:

Total cost of equipment/shelflife

Tableau 21:depreciation cost of equipment

depreciation	unit price	shelflife/years	annual depreciation
building	1000000	20	50000
grating machine	2500000	10	250000
fryer	48000000	10	4800000
press	1200000	10	120000
fermenting rack	500000	10	50000
mechanical sifter	1500000	10	150000
tools	1000000	5	200000
milling machine	3000000	10	300000
toyota hilux	8000000	5	1600000
sealing macine	2000000	10	200000
balance	200000	10	20000
total			7740000

We are the going to estimate the total cost of production which involves raw materials, packaging paper, labour, fuel. This is estimated as shown in the table below.

item	cost of production		total cost/day
	quantity	unit price/Fcfa	
		direct charges	
raw material	5000	50	250000
packages	1500	10	15000
transport bags (50kg)	30	200	6000
direct cost of collection			31300
total 1			302300
		indirect charges	
labour			81600
depreciation		7740000	24807.69231
fuel for toasting, grating, generator	50	520	26000
total 2			132407.6923
grand total	1500	289.8051282	434707.6923

AMELIORATION OF THE LOCAL PRACTICE OF GARI PRODUCTION: CASE STUDY MUYUKA PRODUCTION ZONE

Multiplying this value by 312 (number of working days) gives the total cost of production as **190278800Fcfa.**

Estimation of labour cost is given in annex 11

We then went ahead to estimate the sales income. This is as shown in the table below.

Tableau 22: estimation of sales capital

item	quantity	quantity old/day	unit price	AMOUNT/Fcfa
gari	1500	468000	500	234000000
cassava peelings	1500	468000	25	11700000
total sales income				245700000

Implementing the financing of PIDMA, which says that 50% of the investment is borrowed, it then implies we are going to borrow 50% of 190278800 Fcfa. And paying this sum with a constant annuity gives the following interest rates over a five years investment period.

Table 23: annual interest rate using constant annuity

years	capital	interest	amortissement	annuite
1	95139400	14270910	14110652.67	28381562.67
2	81028747.33	12154312.1	16227250.57	28381562.67
3	64801496.76	9720224.513	18661338.16	28381562.67
4	46140158.6	6921023.79	21460538.88	28381562.67
5	24679619.71	3701942.957	24679619.71	28381562.67
total			95139400	

We then drew up our financial analyses table over period of five years using the following elements:

Tax labeled on enterprise= 38.5%

interest rate $i=15\%$

Gross income= quantity sold* unit price=total sales- total expenses

Taxable income= gross income- depreciation

Net income=taxable income-tax

AMELIORATION OF THE LOCAL PRACTICE OF GARI PRODUCTION: CASE STUDY MUYUKA PRODUCTION ZONE

Cash flow= net income- depreciation

t=time in year

I= invested capital

To determine the viability of project, the following elements were used:

Profitability index (IP) = $\sum CF(1+i)^{-t} / I$

Project is profitable if IP >1

Present Net Value (PNV)= $\sum CF(1+i)^{-t} - I$

From the table we can see that the project is feasible from the second year of investment.

The BEP can be calculated as follows:

$$BEP = n1 + \left(\frac{I - cCFn1}{cCFn2 - cCFn1} \right) (n2 - n1)$$

n is boundary years when CF is positive and IP is greater than 1

Numerical application gives BEP as approximately 1year 6 months.

AMELIORATION OF THE LOCAL PRACTICE OF GARI PRODUCTION: CASE STUDY MUYUKA PRODUCTION ZONE

Tableau 1: previsionary table of project over 5 years

YEAR		1	2	3	4	5
INVESTMENT		190278800				
QUANTITY SOLD (growth rate =0,05)	1.05	936000	982800	1031940	1083537	1137713.85
Sales figure (selling price=)	525	491400000	515970000	541768500	568856925	597299771.3
Total charges (Normal cost=)	242.21	226708560	238043988	1031940	262443496.8	275565671.6
Bank loan						54054600
Interest on bank loan (0,15%)		14270910	12154312.1	9720224.513	6921023.79	3701942.957
Depreciation		7740000	7740000	7740000	7740000	7740000
Non-imposed profit		242680530	258031699.9	523276335.5	291752404.4	256237556.7
Imposition (Taux=38.5%)		93432004.05	99342204.46	201461389.2	112324675.7	98651459.32
Net Profit		149248526	158689495.4	321814946.3	179427728.7	157586097.4
Depreciation		7740000	7740000	7740000	7740000	7740000
CF		156988526	166429495.4	329554946.3	187167728.7	165326097.4
(1+i)-n		0.869565217	0.756143667	0.657516232	0.571753246	0.497176735
Actual CF		136511761.7	125844609	216687726.7	107013756.4	82196289.35
Cumulated CF		136511761.7	262356370.7	479044097.4	586057853.8	668254143.1
NPV		-53767038.3	72077570.73	288765297.4	395779053.8	477975343.1
PI		0.717430222	1.378799797	2.51759049	3.079995532	3.51197371

GENERAL CONCLUSION AND PERSPECTIVES

The major objective of this work was to ameliorate the local practice of gari production. Gari production over the years has been known to be labour intensive. This labour intensive nature translate to low quality products. From the survey results, all producers complained of the frying operation to be time consuming and possess health problems. We were able to propose a frying model of capacity greater than the village fryer and having a chimney for the proper evacuation of smoke and its made of bricks which has a greater insulating effect. Hence the heat intensity upon the processor body will be reduced. This model is also raised up and hence will make better the sitting posture of the fryer. We also propose the use of pre-fermented mash rather than not fermenting the mash in processing. From economic evaluation we saw that the overall result was negative over a year's period. This due to the household and subsistence nature of production.

As perspectives,

- An acceptability test should be carried out on gari samples in addition to the qualitative descriptive analysis to access which gari is preferred by consumers with respect to the parameters that were varied.
- Microbiological analysis be carried out on samples to evaluate microbial load and presence of coliforms of zero tolerance.
- Analyse the presence of heavy metals in gari samples.

AMELIORATION OF THE LOCAL PRACTICE OF GARI PRODUCTION: CASE STUDY MUYUKA PRODUCTION ZONE

REFERENCES

- A.A.C.C (1999). International Method 46-13.01. Crude Protein—Micro-Kjeldahl Method. The Association, Arlington, Va.
- Achidi, A. U., Ajayi, O. A., Bokanga, M., and Maziya-Dixon, B. 2005. The Use of Cassava Leaves as Food in Africa. *Ecology of Food and Nutrition*, 44, 423-435.
- Adegun, I.K., Ajimotokan, H.A. Akinlosoye, A.A and Babarinde, M.S. (2011). Development of a cassava processing plant for producing improved stone-free gari. *Journal of Agricultural Technology* 2011 Vol. 7(5): 1193- 1198.
- Adeleke R.O, Odedeji, J.O (2010). Functional Properties of Wheat and Sweet potato Flour Blends. *Pak. J. Nutr.* 9 (6): 535.
- Ahaotu, I., Ogueke, C.C., Owuamanam, C.I., Ahaotu, N.N. and Nwosu, J.N. (2011). Protein improvement in gari by the use of pure cultures of microorganisms involved in the natural fermentation process. *Pakistan Journal of Biological Sciences.* 14 (20): 933 – 938.
- Akinlosoye, A. A. and Babarinde, M.S. (2009). Design and Fabrication of a Stone-Free Gari Processing Plant”, B. Eng. Thesis, Department of Mechanical Engineering, University of Ilorin, Nigeria.
- Allen, A. C. (2002). The origins and taxonomy of cassava. In Hillocks, R. J., Thresh, J. M. and
- AOAC, (1990). Hydrocyanic Acid In Beans, Alkaline Titration Method. In *Official Methods Of Analysis*, 15th Ed, Aoac, Inc, Arlington, Va, Usa, 1213. Tetchi F. A., Solomen O. W., Célah.
- Apea-Bah F.B., Oduro I., Ellis W.O., Safo-Kantanka O. (2011) Factor Analysis and Age at Harvest Effect on the Quality of Flour from Four Cassava Varieties. *World Journal of Dairy & Food Sciences* 6: 43-54.
- Arlène Alpha, Cécile Broutin, Gret (2009). Normes de qualité pour les produits agroalimentaires en Afrique de l’Ouest. Agence Française de Développement Département de la Recherche.
- Asiedu, J. J. (1990). “Processing Tropical Crops”, ELBS Publishers, London, UK.

AMELIORATION OF THE LOCAL PRACTICE OF GARI PRODUCTION: CASE STUDY MUYUKA PRODUCTION ZONE

- Bainbridge, Z., Tomlins, K., Wellings, K. and Westby, A. (1996). Methods for assessing quality
- Balogopalan C., Padmaja G., Nanda S.K. and Moorthy S.M (1988) Cassava in food, feed, and industry. CRC Press, Boca Raton, Florida USA.
- Balogopalan C., Padmaja G., Nanda S.K. and Moorthy S.M (1988) Cassava in food, feed, and industry. CRC Press, Boca Raton, Florida USA.
- Banea, M., Poulter, N.H., Rosling, H. (1992). Short cuts in cassava processing and risks of dietary cyanide exposure in Zaire. Food and Nutrition Bulletin 14 (2), 137–143.
- Bellotti, A. C. (Eds), Cassava biology, production and utilization. CABI Publishing, Wallingford, UK, 1- 16.
- Bellotti, A. C. (Eds), Cassava biology, production and utilization. CABI Publishing, Wallingford, Uk, 55-66.
- Benesi, I.R.M., (2002): Native starch evaluation and analysis of genetic distance
- Borges, M. F. and Fukuda W. M. G. (1989). Teor de cinetos em raízes frescas e processadas de mandioca. Revista Brasileira de mandioca, 8, Bahia, Brasil, 71-76.
- Bradbury, J. H. and Holloway, W.D. (1988). Chemistry of tropical root crops: significance for nutrition and agriculture in pacific. ACIAR Monograph No 6.
- Bruijn, G. H. (1971). Étude du caractère cyanogénétique du manioc. Meded Landb Hogesch Wageningen 71, Wageningen, The Netherlands.
- Buitrago A.J.A. (1990). La yucca en la alimentacion animal. Centro Internacional de Agricultura Tropical, Cali, Colombia, 446 p.
- C.I. Owuamanam, A.D. Hart and I.S. Barimalaa, L.I. Barber and S.C. Achinewhu, (2010). Nutritional Evaluation of Gari Diets from Varying Fermentation Time Using Animal Model; Researcher. 2(8):1-10.
- CABI Publishing, Wallingford, UK, 17-40
- CABI Publishing, Wallingford, UK, 281-300.

AMELIORATION OF THE LOCAL PRACTICE OF GARI PRODUCTION: CASE STUDY MUYUKA PRODUCTION ZONE

- Cabrera E., Pineda J.C., Duran de Bazua., Segurajuaregui J.S and Vernon E.J. (1984). Kinetics of water diffusion and starch gelatinisation during nixtamalisation. In proceedings of the third internal congress of Engineering and Food. 26-28 Sept. 1983 at Trinity.
- Caisse Française de Développement (CFD) (1998). Étude des potentiels techniques et économiques de la transformation primaire des tubercules vivriers dans la région de l’Afrique de l’Ouest, étude exploratoire au Bénin, mars.
- characteristics of non-grain starch staples. (Part 2. Field Methods.). Methods for assessing quality characteristics of non-grain starch staples. Natural Resources Institute, Chatham, Kent. ISBN 0-85954-400-1.
- Chika C. Ogueke, Chisom Ehirim, Clifford I. Owuamanam, Ihuoma Ahaotu and Ijeoma A. Olawuni (2013). Quality Characteristics and HCN in Gari as Affected by Fermentation Variables. *International Journal of Life Sciences* Vol.2. No.1. 2013. Pp. 21-28.
- Chiwona-Karlton, L. and Mkumbira, J. (2000). Low dietary cyanogen exposure from frequent consumption of potentially toxic cassava in Malawi. *International Journal of Food Sciences & Nutrition*, 51, 33-43.
- Chuzel, G., (1991). Cassava starch : current and potential use in Latin America. *Cassava News letter*, 15(1), 9-11.
- Conn, E.E. (1994). Cyanogenesis- a personal perspective. In Bokanga, M., Essers, A. J. A., Poulter, N., Rosling, H. and Tewe, O. (eds), *Proceedings of the international workshop on cassava safety*, March 1-4, 1994, Ibadan, Nigeria, *Acta Horticulturae*, 375, 31-43.
- Corporate Document Repository No. 45.
- Cranta) in the Humid Tropics of West Africa. *Food and Nutrition Bulletin*, 2(4): 1-12.
- Dahniya, M. T. (1994). An overview of cassava in Africa. *Crop science journal*, Makerere University, Uganda, 2, 337-343.
- Delange F., Ekpechi L.O., Rosling H. (1994). Cassava cyanogenesis and iodine deficiency disorders. *Acta Horticulturae* 375:289–93.
- Diop, A. (1998). *Storage and Processing of Roots and Tubers in the Tropics*. FAO
- Dufour D.L., (1988). Cyanide content of cassava (*Manihot esculenta* Euphorbiaceae) cultivars used by Tukanoan Indians in northwest Amazonia. *Econ Botany* 42:255–66.

AMELIORATION OF THE LOCAL PRACTICE OF GARI PRODUCTION: CASE STUDY MUYUKA PRODUCTION ZONE

- E.O. (2004). The microflora of fermented nixtamalized corn. *International Journal of*
- Elijah I. Ohimain, Daniel I. Silas-Olu, and Joy T. Zipamoh, (2013). Biowastes Generation by Small Scale Cassava Processing Centres in Wilberforce Island, Bayelsa State, Nigeria. *Greener Journal of Environmental Management and Public Safety*, Vol. 2 (1), pp. 051-059.
- Emmanuel Njukwe, O. Onadipe, D. Amadou Thierno³, R. Hanna², H. Kirscht, B. Maziya-Dixon, S. Araki, A. Mbairanodji and T. Ngue-Bissa. (2014). Cassava processing among small-holder farmers in Cameroon: Opportunities and challenges. *International Journal of Agricultural Policy and Research* Vol.2 (4), pp. 113-124.
- Ernesto M., Cardoso A.P., Nicala D., Mirione E., Massaza F., Cliff J., Haque M.R. and Bradbury J.H., (2002). Persistent konzo and cyanogen toxicity from cassava in northern Mozambique. *Acta Tropica.*, 82, 3, 357-362.
- Ernesto, M. Cardoso, A.P. Cliff, J. and Bradbury, J.H. (2000) Cyanogens in cassava flour and roots and urinary thiocyanate concentration in Mozambique, *Journal of Food Composition and Analysis*, 13, 1-12.
- Falade K., Akingbala J. (2010): Utilization of Cassava for Food, *Food Reviews International*, 27:1, 51-83.
- FAO, (2012). <http://faostat.fao.org>. Agricultural Statistics. Food and Agricultural Organization of the United Nations. Rome [15 September 2012].
- FAOSTAT: Production-Crops, 2010 data". Food and Agriculture Organization of the United Nations. 2011.
- FIIRO, (2006). Cassava: production, processing and utilisation in Nigeria. Federal Institute of Industrial Research, Oshodi Lagos Nigeria. 27-163.
- Food Microbiology*, 96 (1), pp. 97-102.
- Gade, D.W., (2002). Names for manihot esculenta: Geographical variations and lexical clarification. *J. Latin Am. Geograph.*, 1(1): 55-74.
- Gbasouzor Austin Ikechukwu and A. I. V. Maduabum, (2012). Improved Mechanized Gari Frying Technology for Sustainable Economic Development in Nigeria. *Proceedings of IMECS vol II, Hong Kong.*

AMELIORATION OF THE LOCAL PRACTICE OF GARI PRODUCTION: CASE STUDY MUYUKA PRODUCTION ZONE

- Gbasouzor Austin Ikechukwu, A. I. V. Maduabum, (2012). Improved Mechanized Gari Frying Technology for Sustainable Economic Development in Nigeria. Proceedings of the International MultiConference of Engineers and Computer Scientists, Vol. II, IMECS, Hong Kong.
- Grace, M.R. (1977). Cassava Processing. Food and Agriculture Organisation (FAO) of United Nation Plant Production and Protection Series No.3, available at <http://www.fao.org/docrep/X5032E/x5032E01.htm#Introduction> (accessed August 14, 2009).
- Henry, G. and Hershey, C. (2002). Cassava in South America and Caribbean. In Hillocks, R. J., Thresh, J.M. and Bellotti, A. C. (Eds), Cassava biology, production and utilization.
- Hillocks R.J. (2002). Cassava in Africa. In: Cassava Biology, Production and Utilization eds. Hillocks RJ , Thresh JM and Bellotti AC CABI Publishing, Oxon, New York.
- IITA, (1990): Cassava in Tropical Africa. A reference Manual. Balding and Mansell International, Wesbech, UK. pp.176.
- IITA, (2005). Cassava utilization: Gari. Available <http://www.cassavabiz.org/postharvest/Gari>. (Accessed August 14, 2009).
- Islam, A. K. M. S., Edwards, D. G. and Asher, C. J. (1980). pH optima for crop growth: Results of flowing culture experiment with six species.
- Jones, K. A., Westby, A., Reilly, P. J. A. and Jeger, M. J., (1993). The exploitation of
- Jones, W.O. (1959). Manioc in Africa. Stanford University Press, Stanford.
- King, N.L.R. and Bradbury, J.H., (1995). Bitterness of cassava: identification of new apiosyl glycoside and other compounds that affect its bitter taste. Journal of the Science of Food and Agriculture, 68, 223-230.
- Komolafe E.A. and Arawande J.O. (2010). Evaluation of the quantity and quality of gari produced from three cultivars of cassava. Journal of Research in National Development 8.
- Lebot, V. (2008). Ameliorer les plantes a racines et tubercules tropicales. Cirad. 2 P.

AMELIORATION OF THE LOCAL PRACTICE OF GARI PRODUCTION: CASE STUDY MUYUKA PRODUCTION ZONE

- Leitão, A. B. (1970). A mandioca no sul do Save. Comunicações, INIA, Lourenço Marques, Moçambique.
- Lozano, J.C., Byme D. and Bellotti, A. (1980): Cassava and ecosystem relationships and their influence on breeding strategy. *Tropical Pest Management* 26: 180-187.
- Lutaladio, N.B. and Ezumah, H.C. (1981). Cassava leaf harvesting in Zaire. In: Terry, E.R., Oduri, K.A. and Caveness, F. (eds) *Tropical Root Crops: Research Strategies for the 1980s*. IDRC, Ottawa Canada, pp. 134-136.
- Makkar, H. P. S., Siddhuraju, P. & Becker, K. (2007). Plant Secondary Metabolites. In *Methods In Molecular Biology*. Humana Press Inc., Totowa, Nj, Vol. 393, Pp. 61-68.
- Mamoudou H. Dicko, (2006). Travaux pratiques Biochimie Structurales et Enzymologie. Centre De Recherche En Sciences Biologiques Alimentaires Et Nutritionnelles. Pp 4-6.
- Maziya-Dixon, B., Dixon, A. G. O. and Adebowale, A. A. (2007). Targeting different uses of cassava: genotypic variations for cyanogenic potentials and pasting properties. *International Journal of Food Science and Technology*. 42(8): 969 – 976.
- McMahon, J.M., White, W.L. B., and Sayre, R.T. (1995). Review article. *Journal of Experimental Botany*, 46, 731-741.
- microorganisms in developing countries of the tropics. In Jones D. G. (ed) *Exploitation Minader / Desa / Agr-Stat N°17 Juillet 2012*.
- Mlingi, N.L.V., Poulter, N.H., Rosling, H. (1992). An outbreak of acute intoxication from insufficiently processed cassava in Tanzania. *Nutrition Research* 12, 677–687.
- N. R. I. (Natural Resources Institute), (1989). Processing research on cassava in Africa. In: Nweke, F.I., Lynan, F., Prudencio, C. (Eds.), *Methodologies and data requirement for cassava systems study in Africa, Collaborative Study of Cassava in Africa (COSCA)*, Working Paper No. 4, IITA, Ibadan, Nigeria.
- Nago, C.M. (1995), « La préparation artisanale du gari au Bénin: Aspects technologiques et physico-chimiques », in Agbor, E., A. Brauman, D. Griffon et S. Treche, *Transformation alimentaire du manioc*, Orstom, Paris.

AMELIORATION OF THE LOCAL PRACTICE OF GARI PRODUCTION: CASE STUDY MUYUKA PRODUCTION ZONE

- Nambisan, B., and Sundaresan, S. (1994). Distribution of linamarin and its metabolising enzymes in cassava tissues. *J. Sci. Food Agric.*, 66, 503-507
- Nassar, N.M.A. and. Costa, C.P (1976): Tuber formation and protein content in some wild cassava (mandioca) species native to central Brazil. *Experientia* 33: 1304-1306.
- Nassar, N.M.A., (1986): Genetic variation of wild *Manihot* species native to Brazil and its potential for cassava improvement. *Field Crops Research* 13: 177-184.
- Nassar, N.M.A., (2005): Cassava: Some ecological and physiological aspects related to plant breeding. An article published online with Gene Conserve.
- Nelson, D.L. and Cox, M.M. (2008). *Lehninger principles of biochemistry*. W H Freeman. 5th Edition, USA. 1100 p.
- Njukwe E., Onadipe O., Thierno D.A., Hanna R., Kirscht H., Maziya-Dixon B., Araki S., Mbairanodji A., Ngue-Bissa T. (2014). Cassava processing among small-holder farmers in Cameroon: Opportunities and challenges. *Int. J. Agric. Pol. Res.* 2(4):113-124.
- Nweke, F. I. (1994). Cassava distribution in Africa. Study of cassava in Africa. IITA, Ibadan, Nigeria, work paper no 12.
- Nweke, F. I. (1994). Cassava distribution in Africa. Study of cassava in Africa. IITA, Ibadan, Nigeria, work paper no 12.
- Nweke, F. I.; Spencer, D. S. C. and Lynam, J. K. (2002). The cassava transformation Africa's best kept secret. Michigan state University Press East Lansing USA pp 7 – 206.
- Nweke, F.I., (1994). Processing potentials for cassava production growth. COSCA Working Paper No. 11, Collaborative Study of Cassava in Africa, IITA, Ibadan, Nigeria.
- Nyirenda, D.B., Chiwona-Karlton, L., Chitundu, M., Haggblade, S., and Brimer, L. (2011). Chemical safety of cassava products in regions adopting cassava production and processing - Experience from Southern Africa. *Food and Chemical Toxicology*, 49, 607-612.
- Oduro, I., Ellis, W.O., Dziedzoave, N.T. and Nimako-Yeboah, K. (2000). Quality of Gari from Selected Processing Zones In Ghana. *Food Contrl J.* 11: 297-303.

AMELIORATION OF THE LOCAL PRACTICE OF GARI PRODUCTION: CASE STUDY MUYUKA PRODUCTION ZONE

Oduro, W.O. Ellis, N.T. Dziedzoave, and K. Nimako-Yeboah, (2000). Quality of gari from selected processing zones in Ghana. *Food Control* (11) 297-303.

of Microorganisms, Chapman and Hall, London.

Okigbo, B. (1980). Nutritional implications of projects giving high priority to

Olsen K.M. and Schaal B.A. (1999). Evidence on the origin of cassava: phylogeography of *Manihot esculenta*. *Proc. Natl. Acad. Sci.* 96: 5586-5591

Omodamiro R.M., Iwe M.O., Ukpabi U.J. (2007). Pasting and functional properties of lafun and starch processed from some improved cassava genotypes in Nigeria. *Niger. Food J* 25(2) : 122-129.

Onwueme, I. C. (2002). Cassava in Asia and the Pacific. In Hillocks, R.J., Thresh, J. M. and

Onwueme, I.C., (1978): *The Tropical Tuber Crops: Yams, Cassava, Sweet potato, Cocoyam's*. John Wiley and Sons Ltd. pp.234.

Osuntakan, B.O. (1994). Chronic cyanide intoxication of dietary origin and a degenerate neuropathy in Nigerians. *Acta Horticulturae* 375, 311-321.

Oti, Emmanuel; Onadipe Olapeju; Ms. Sébastienne Dohou; Egounlety Moutairou; Detouc Nankagninou; Gregory Afra Komlaga; and Guy Médard LOUEKE, (2011). *Training Manual: Processing of Cassava into Gari and High Quality Cassava Flour in West Africa*. Guy Médard LOUEKE, Agro Economist Engineer Centre Songhaï.

Plant and soil, 54, 339-357 production of staples of low nutritive quality: The case for cassava (*Manihot esculenta*)

R.M. Davies, M.O. Olatunji and W. Burubai (2008). A Survey of Cassava Processing Machinery in Oyo State. *World Journal of Agricultural Sciences* 4 (3): 337-340.

Rosling, H. (1988). Cassava toxicity and food security – A review of health effects of cyanide exposure from cassava and of ways to prevent such effects. Uppsala, International Child Health Unit, Uppsala University.

Ruiz, R., (1995). La agroindustria del almidon agro enel norte del cauca. In : taller “avances cobre almidon de yuca”. Resumenes, CIAT, calc, Colombia 17-20 junio, 7p.

AMELIORATION OF THE LOCAL PRACTICE OF GARI PRODUCTION: CASE STUDY MUYUKA PRODUCTION ZONE

- Sanni, M.O., Sobaminwa, A.O., Modupe, C.E. and Rosling, H. (1994). Safety Aspects of Processing Cassava to Gari in Nigeria” *Acta Horticulturae* 375:227-232.
- Sanyang, Sidi, Rhiannon Pyburn, Remco Mur and Geneviève Audet-Bélanger (editors). 2014. *Against the grain and to the roots: Maize and cassava innovation platforms in West and Central Africa*. LM Publishers, Arnhem.
- Sefa-Dedeh, S., Cornelius, B., Amoa -Awua, W., Sakyi-Dawson. E.O. and Afoakwa, Simeu Kamdem M., (1996). Le manioc au Cameroun, une filière vivrière autorégulée. *Cahiers "Agricultures"*, . 5(4) : 257-264.
- Teles, F.F. F. (1995). Toxicidade crônica da mandioca na África e América Latina. *Revista Brasileira de mandioca* 1, CNPMF, Bahia, Brasil. 107-116.
- Tewe O.O., Lutaladio N. (2004). *Cassava for livestock feed in sub-Saharan Africa*. Rome, Italy: FAO.
- Thresh, J.M. and Bellotti, A. C. (Eds), *Cassava biology, production and utilization*.
- Tiky Mpondo G, (1993). Analyse des coûts/bénéfices de petites unités villageoises de transformation de manioc en gari et de viabilité économique d'une entreprise privée de conditionnement et de commercialisation du gari. Yaoundé: Institut de la Recherche Agronomique (INRA) ; 63 p.
- Tomlins K.I., Owori C., Bechoff A., Menya G., and Westby A. Relationship among the carotenoids content, dry matter content and sensory attributes of sweet potato. *Food Chemistry* 131: 14–21.
- Tylleskar, T. (1994). The association between cassava and the paralytic disease konzo. *Acta Horticulture* 375, 321–331.
- Udoro, E.O., Kehinde A.T., Olasunkanmi S.G., Charles T.A. (2014). Studies on the Physicochemical, Functional and Sensory Properties of Gari Processed from Dried Cassava Chips. *J Food Process Technol* 5: 293. doi:10.4172/2157-7110.1000293.

URL <http://www.geneconserve.pro.br/>.

AMELIORATION OF THE LOCAL PRACTICE OF GARI PRODUCTION: CASE STUDY MUYUKA PRODUCTION ZONE

using AFLP of elite cassava (*Manihot esculenta* Crantz) genotypes from Malawi. MSc Thesis in Plant Breeding, Department of Plant Sciences (Plant Breeding) Faculty of Natural and Agricultural Sciences, University of the Free State, Bloemfontein, South Africa.

Wenham J.E., (1995). Post harvest deterioration of cassava. A biotechnological perspective. FAO plant and protection paper 130 Rome.

Westby, A. (2002). Cassava utilization, storage and small-scale processing. In Hillocks, R. J.,

Wheatley, C.C. and Chuzel, G. (1993). Cassava: the nature of the tuber and use as raw material. In: Macrere, R., Robinson, R.K. and Sadler, M.J. (eds). Encyclopedia of Food Science, Food Technology and Nutrition. Academic press, San Diego, California, pp 734-743.

White, W.L. B., McMahon, J. M. and Sayre, R. T. (1994). Regulation of cyanogenesis in cassava. In Bokanga, M., Essers, A. J. A., Poulter, N., Rosling, H. and Tewe, O. (eds), Proceedings of the international workshop on cassava safety, March 1-4, 1994, Ibadan, Nigeria, *Acta Horticulturae*, 375, 69-77.

Wilhemina Quaye, J. Gayin, I. Yawson and W.A. Plahar, (2009). Characteristics of Various Cassava Processing Methods and the Adoption Requirements in Ghana. *Journal of Root Crops*, Vol. 35 No. 1, pp. 59-68

William, C.E., (1979). Role of women in cassava processing in Nigeria. In (Plundenet) small scale processing and storage of tropical root crop. Published by Westview Press Columbia.

Wobeto C., Correa A.D., de Abreu C.M.P., dos Santos C.D., Pereira H.V. (2007). Antinutrients in the cassava (*Manihot esculenta* Crantz) leaf powder at three ages of the plant. *Cienc Technol Aliment* 27:108-12.

AMELIORATION OF THE LOCAL PRACTICE OF GARI PRODUCTION: CASE STUDY MUYUKA PRODUCTION ZONE

ANNEXES

Annex 1: Post traditional method Gari production

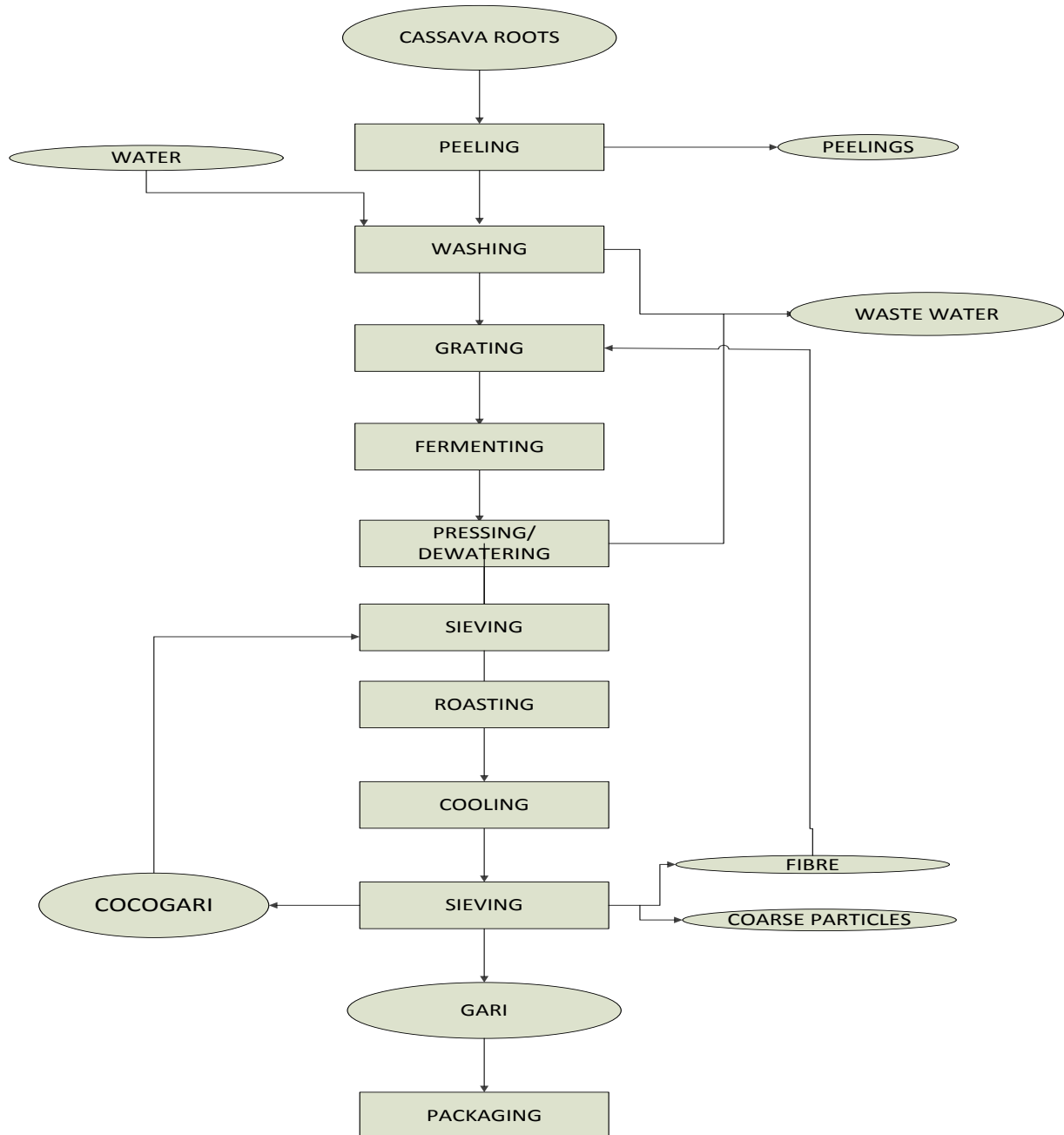

Post Traditional Basic Process for Gari Manufacture. (From Cook *et al.*, 1975; Williams, 1975)

AMELIORATION OF THE LOCAL PRACTICE OF GARI PRODUCTION: CASE STUDY MUYUKA PRODUCTION ZONE

Annex 2: modern method of Gari production

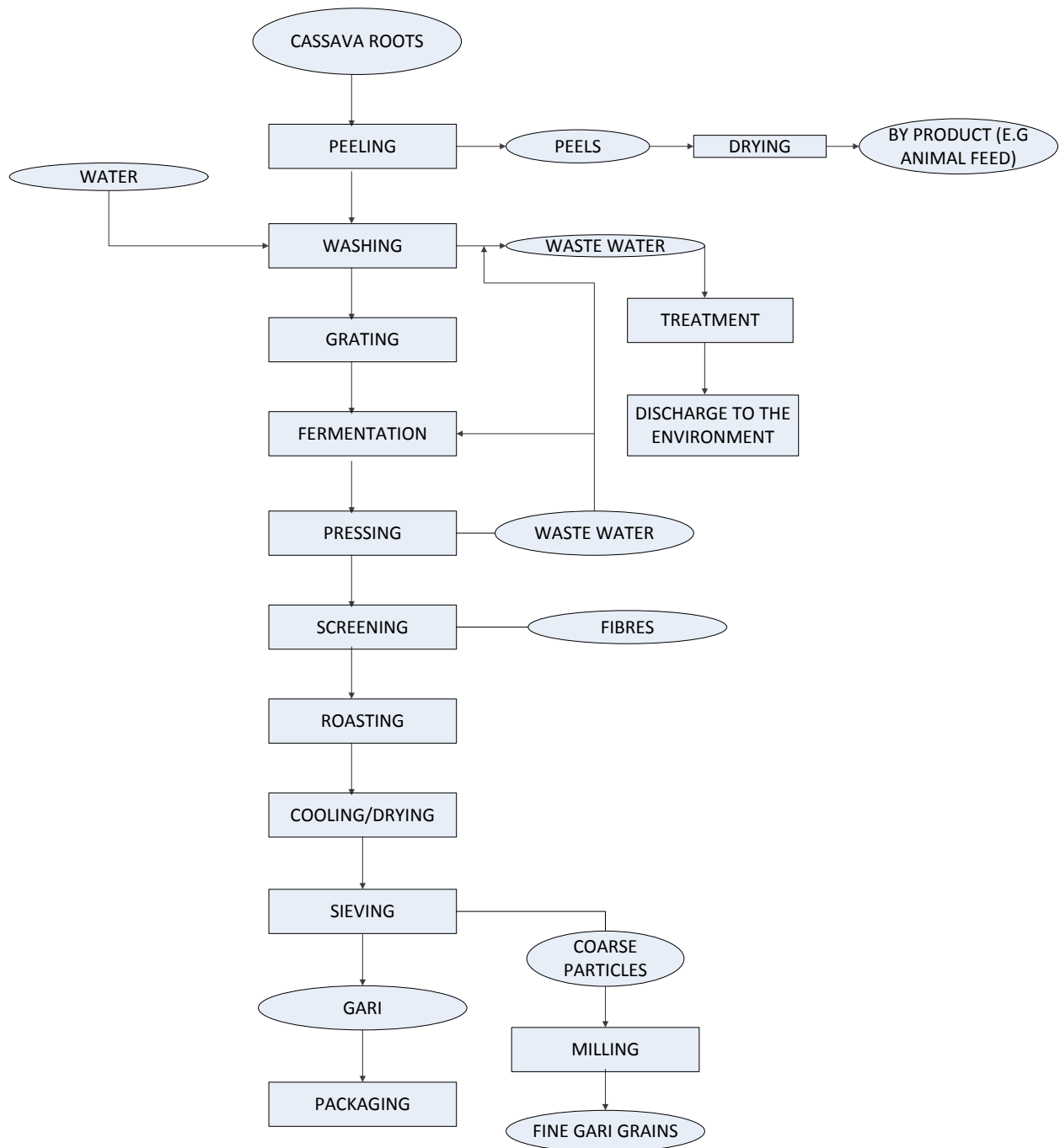

Modern technology of gari processing

**AMELIORATION OF THE LOCAL PRACTICE OF GARI PRODUCTION: CASE
STUDY MUYUKA PRODUCTION ZONE**

Annex 3: Definition of terms of Sensory analysis

Sensory attribute	definition	Testing method
aspect	Color ranging from white to yellow Homogeneity in color Grain granulometry Homogeneity in granulometry Presence of fibres	The product is looked with the eyes
Touch	What is felt when gari sample is touched with the fingers	Gari is put into the hand, felt with the fingers and criteria evaluated
odour	Gari of gari Fermented cassava odour Mold odour	The product is smelled and criteria jugde
taste	Sweetness Sourness Raw cassava mold	Gari sample is put into the mouth and criteria evaluated
Texture in the mouth	Granular Hard meltability	gari sample is put into the mouth and and then criteria evaluated

AMELIORATION OF THE LOCAL PRACTICE OF GARI PRODUCTION: CASE STUDY MUYUKA PRODUCTION ZONE

Annex 4: Sensory Evaluation form

Nom _____

Date _____

Nous vous proposons quatre échantillons de gari à tester l'un après l'autre. Pour chacun d'eux, évaluez l'intensité de chacun des descripteurs en utilisant l'échelle ci-dessous.

Indiquez la note de l'intensité choisie par un trait vertical au-dessus duquel vous noterez le numéro de l'échantillon.

Chaque ligne de descripteur comprendra quatre notes correspondant à chaque échantillon.

Nous vous recommandons de vous rincer la bouche entre chaque échantillon pour une meilleure évaluation.

Evaluer les échantillons dans l'ordre indiqué ci-dessous

Ordre des échantillons 1er _____ 2eme _____ 3eme _____ 4ème _____

Descripteurs

Apparence

Couleur Blanc |-----| Jaune

Homogénéité Moins homogène |-----| Plus homogène

Finesse Granuleux |-----| Fin

Homogénéité texture Moins homogène |-----| Plus homogène

Présence de fibres Sans fibres |-----| beaucoup de fibres

Texture au toucher

Finesse Granuleux |-----| Fin

Odeur

Odeur de gari Faible |-----| Intense

Odeur de manioc fermenté Faible |-----| Intense

Odeur de moisi Pas moisi |-----| Moisi

Goût

Goût acide Faible |-----| Fort

Sucré faible |-----| Fort

Goût de manioc cru faible |-----| Fort

Goût de moisi faible |-----| Fort

Texture dans la bouche

Finesse Granuleux |-----| Fin

Dureté des grains Dur |-----| Tendre/mou

Fondant Moins fondant |-----| Plus fondant

Commentaires

AMELIORATION OF THE LOCAL PRACTICE OF GARI PRODUCTION: CASE STUDY MUYUKA PRODUCTION ZONE

Annex 5: Correlation table of sensory attributes of gari as perceived by panelists

Values in bold and underlined are significantly different from zero, $\alpha=0.0$

Variables	Couleur	Homogénéité app	Finesse app	Homogénéité texture	Présence fibres	Finesse toucher	Odeur de gari	Odeur manioc fermenté	Odeur moisie	Goût acide	Goût sucré	Goût Manioc cru	Goût moisie	Finesse en bouche	Dureté grain bouche	Fondant
Couleur	1															
Homogénéité app	-0.488	1														
Finesse app	-0.763	0.221	1													
Homogénéité texture	-0.609	0.323	0.937	1												
Présence fibres	-0.591	0.024	0.269	0.021	1											
Finesse toucher	-0.772	0.312	0.990	0.929	0.243	1										
Odeur de gari	0.944	-0.576	-0.761	-0.672	-0.379	-0.785	1									
Odeur manioc fermenté	0.387	-0.543	-0.205	-0.259	-0.225	-0.228	0.456	1								
Odeur moisie	-0.518	0.358	0.308	0.154	0.330	0.352	0.347	0.161	1							
Goût acide	0.438	-0.240	-0.061	0.020	-0.223	-0.074	0.447	0.045	0.004	1						
Goût sucré	0.492	-0.063	-0.736	-0.634	-0.203	-0.729	0.465	0.182	-0.38	0.462	1					
Goût Manioc cru	-0.842	0.228	0.811	0.658	0.335	0.821	-0.81	0.044	0.48	-0.42	0.50	1				
Goût moisie	-0.709	0.180	0.642	0.411	0.418	0.684	-0.59	0.137	0.78	-0.19	0.56	0.838	1			
Finesse en bouche	-0.799	0.285	0.993	0.918	0.283	0.994	-0.79	-0.218	0.356	-0.10	0.72	0.842	0.685	1		
Dureté grain bouche	-0.858	0.332	0.957	0.862	0.435	0.952	0.832	-0.339	0.384	0.065	0.73	0.791	0.65	0.969	1	
Fondant	-0.816	0.239	0.969	0.863	0.312	0.965	-0.79	-0.139	0.37	-0.18	0.68	0.882	0.71	0.985	0.953	1

AMELIORATION OF THE LOCAL PRACTICE OF GARI PRODUCTION: CASE STUDY MUYUKA PRODUCTION ZONE

Annex 6: standard curve for HCN

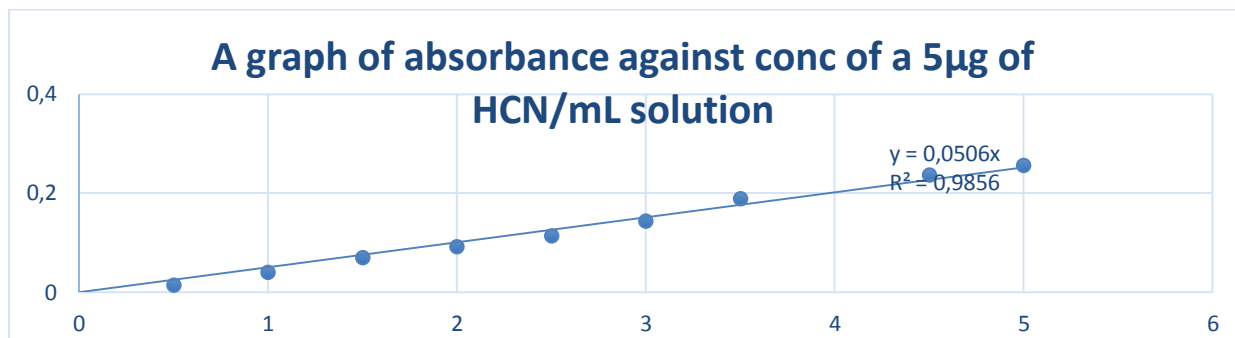

ANNEX 7: standard for starch quantification

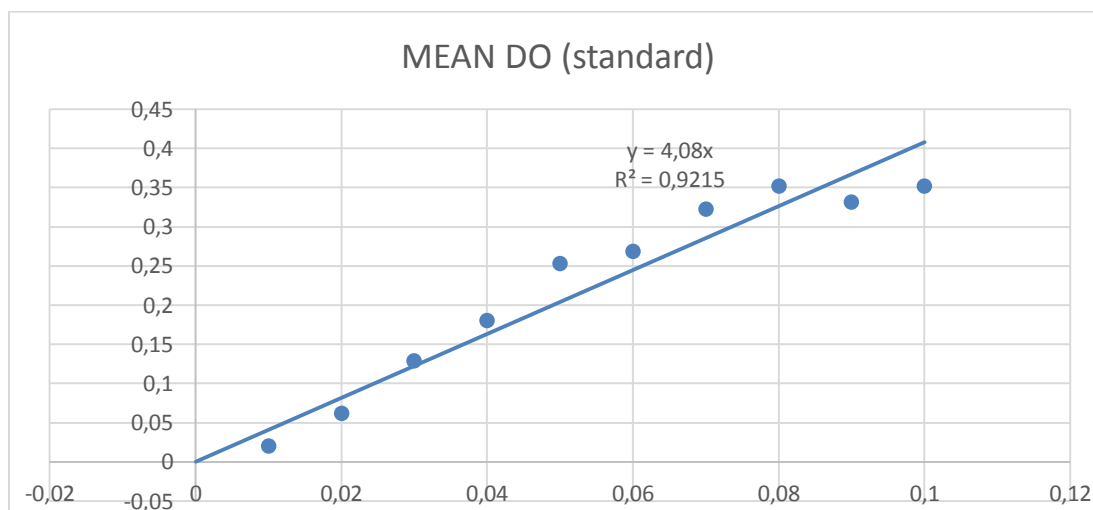

ANNEX 8 standard curve for amylose quantification

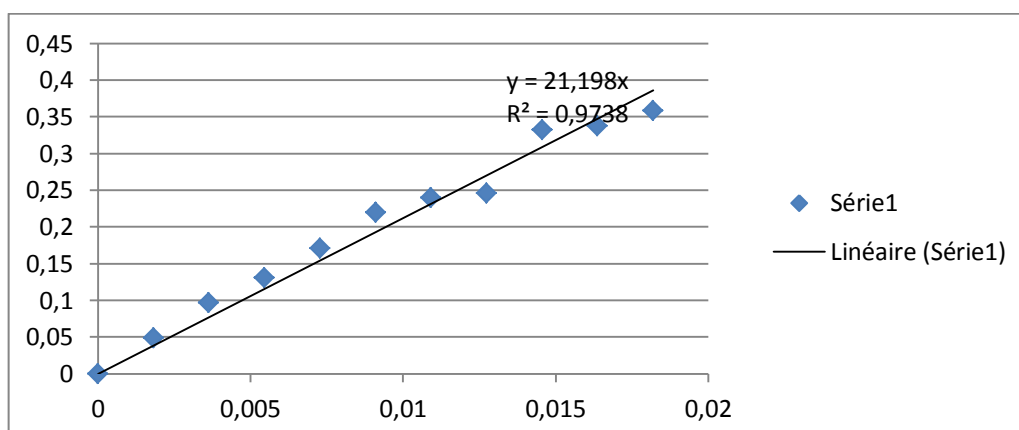

AMELIORATION OF THE LOCAL PRACTICE OF GARI PRODUCTION: CASE STUDY MUYUKA PRODUCTION ZONE

Annex 9: Some survey photos



PEELING OPREATION

WASHING OF ROOTS



GRATING OPERATION



FERMENTATION

PRESSING OPERATION



FRYING OPERATION

AMELIORATION OF THE LOCAL PRACTICE OF GARI PRODUCTION: CASE STUDY MUYUKA PRODUCTION ZONE

Annex 10: Survey questionnaire

e

OPERATIONS AND PRODUCT QUALITY	
<p>45. operations that if poorly carried out can affect products quality</p> <div style="border: 1px solid black; height: 20px; width: 100%;"></div>	<p>47. if others practice</p> <div style="border: 1px solid black; height: 20px; width: 100%;"></div>
<p>46. quality criteria to evaluate final and inter mediate product</p> <p> <input type="checkbox"/> 1.appearance (color) <input type="checkbox"/> 2. taste <input type="checkbox"/> 3.flavor <input type="checkbox"/> 4.dryness <input type="checkbox"/> 5 texture <input type="checkbox"/> 6.others </p> <p><i>Vous pouvez cocher plusieurs cases.</i></p>	
DIFFICULT OPERATIONS	
<p>48. which are the most difficult operations in gari processing and their characteristics</p> <div style="border: 1px solid black; height: 40px; width: 100%;"></div>	
SUPPLEMENTARY QUESTIONS	
<p>49. what are your sources of labour</p> <p> <input type="checkbox"/> 1.hired casual <input type="checkbox"/> 2.exchanged labour <input type="checkbox"/> 3.hired permanent <input type="checkbox"/> 4.hired contract <input type="checkbox"/> 5 family members (children) <input type="checkbox"/> 6 others </p> <p><i>Vous pouvez cocher plusieurs cases.</i></p>	<p>54. how do you peel your cassava</p> <p> <input type="checkbox"/> 1.machine <input type="checkbox"/> 2 manually </p> <p><i>Vous pouvez cocher plusieurs cases.</i></p>
<p>50. if others practice</p> <div style="border: 1px solid black; height: 20px; width: 100%;"></div>	<p>55. if manually (hand) its how its been done</p> <p> <input type="checkbox"/> 1.unrolling the peel with fingers or knife <input type="checkbox"/> 2.sharpening pencil method </p> <p><i>Vous pouvez cocher plusieurs cases.</i></p>
<p>51. how many people participate in gari production in your unit</p> <div style="border: 1px solid black; width: 100%;"></div> <p><i>In réponse de la question précédente (nr 20).</i></p>	<p>56. how do you fry the mash</p> <p> <input type="checkbox"/> 1.mechanical <input type="checkbox"/> 2 manual </p> <p><i>Vous pouvez cocher plusieurs cases.</i></p>
<p>52. how do you finance your processing activity</p> <p> <input type="checkbox"/> 1.owned resources <input type="checkbox"/> 2 bank loan <input type="checkbox"/> 3.cooperative society <input type="checkbox"/> 4 credit union <input type="checkbox"/> 5 others </p> <p><i>Vous pouvez cocher plusieurs cases.</i></p>	<p>57. if manual what is the output rate</p> <p> <input type="radio"/> 1.1 bag/1hour/person <input type="radio"/> 2.1 bag/1day/person </p>
<p>53. if others specify</p> <div style="border: 1px solid black; height: 20px; width: 100%;"></div>	<p>58. which steps in your process need improvement</p> <div style="border: 1px solid black; height: 20px; width: 100%;"></div>
	<p>59. is gari business beneficial</p> <p> <input type="radio"/> 1. Yes <input type="radio"/> 2. No </p>

AMELIORATION OF THE LOCAL PRACTICE OF GARI PRODUCTION: CASE STUDY MUYUKA PRODUCTION ZONE

Annex 11: estimation of personel remuneration

personel	number required	hourly cost/person	total daily cost	daily working hours	total
process engineer	1	1500	1500	8	12000
maintenance technician	2	1500	3000	8	24000
secretary	1	1500	1500	8	12000
unskilled labour	20	200	4000	8	32000
hilux driver	1	200	200	8	1600
total			10200		81600